

# The Use of AASHTO LRFD Bridge Design Specifications with Culverts



Josh Beakley  
November, 2010

# LRFD is Required

June 28<sup>th</sup>, 2000 FHWA Memo

2. All new culverts, retaining walls, and other standard structures on which States initiate preliminary engineering after October 1, 2010, shall be designed by LRFD Specifications, with the assumption that the specifications and software for these structures are "mature" at this time.

**AASHTO**  
**Design**  
**Specifications**

# AASHTO Standard Specifications for Highway Bridges

- Section 3 – Loads
- Section 6 – Culverts
- Section 8 – Reinforced Concrete
- Section 12 – Soil-Corrugated Metal Structure Interaction Systems
- Section 16 – Soil-Reinforced Concrete Structure Interaction Systems
- Section 17 – Soil-Thermoplastic Pipe Interaction Systems

# AASHTO LRFD Bridge Design Specifications

- Section 3 – Loads and Load Factors
- Section 4 – Structural Analysis and Evaluation
- Section 5 – Concrete Structures
- Section 12 – Buried Structures and Tunnel Liners

# Structures Designed Per Section 12

- Section 12.7 - Metal Pipe, Pipe Arch, and Arch Structures
- Section 12.8 - Long-Span Structural Plate Structures
- Section 12.9 - Structural Plate Box Structures
- Section 12.12 – Thermoplastic Pipes
- Section 12.13 – Steel Tunnel Liner Plate

# Concrete Structures Designed Per Section 12

- Section 12.10 – Reinforced Concrete Pipe
- Section 12.11 - Precast Box Culverts, Cast-in-place Box Culverts, Cast-in-place Arches
- Section 12.14 - Precast Three-Sided Structures

# What We Will Discuss

- Loads
- Load Factors
- Load Modifiers
- Capacity Calculations

# Live Load

# Live Load

- 3.6.1.2 Design Vehicular Live Load
  - ◆ 3.6.1.2.1 General
  - ◆ “Vehicular live loading on the roadways of bridges or incidental structures, designated HL-93, shall consist of a combination of:
    - ◆ Design truck or design tandem, and
    - ◆ Design lane load

# Live Load Spacing – HL-93

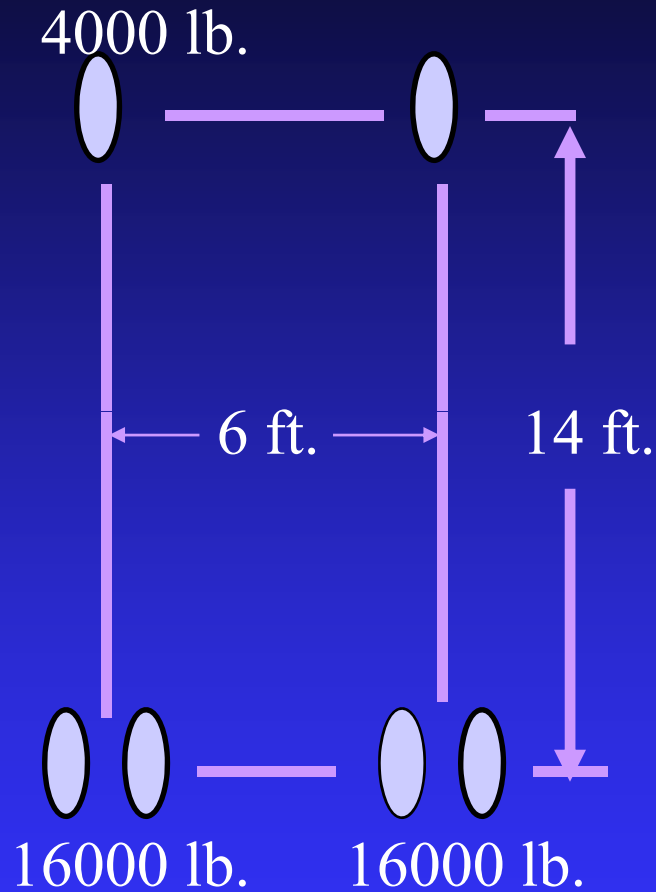

**AASHTO  
HS 20 LOAD**

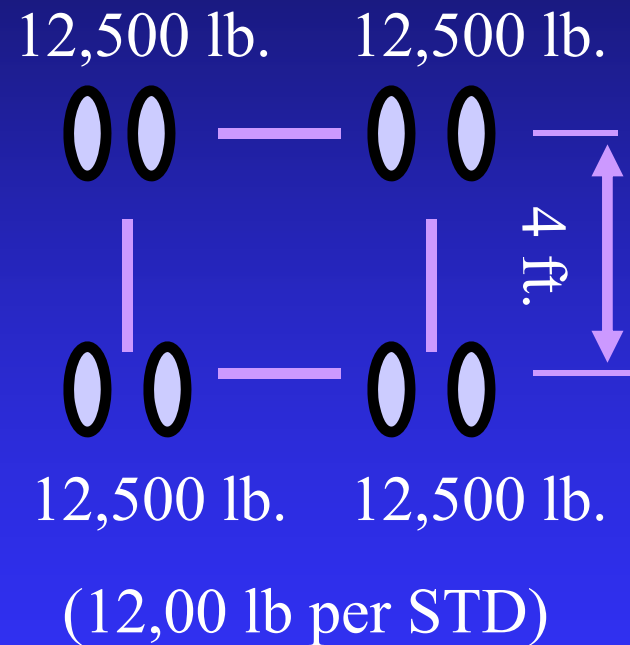

**AASHTO  
ALTERNATE LOAD**

# Applied Live loads – No Lane Load

- 3.6.1.3.3 Design Loads for Decks, Deck Systems, and the Top Slabs of Box Culverts
  - ◆ Where the slab spans primarily in the longitudinal direction:
  - ◆ For top slabs of box culverts of all spans and for all other cases, including slab-type bridges where the span does not exceed 15.0 ft, only the axle loads of the design truck or design tandem of Articles 3.6.1.2.2 and 3.6.1.2.3, respectively, shall be applied.

# Applied Live loads – No Lane Load

- 3.6.1.3.3 Design Loads for Decks, Deck Systems, and the Top Slabs of Box Culverts
  - ◆ Where the slab spans primarily in the transverse direction, only the axles of the design truck of Article 3.6.1.2.2 or design tandem of Article 3.6.1.2.3 shall be applied to the deck slab or the top of box culverts.

## Lane Load – 3.6.1.3

- LRFD – 2004 – Truck and Lane Load
  - ◆ 64 lbs across a 10 ft width
  - ◆ DLA not applied
- LRFD – 2005 – Truck only
- Standard Specification – 3.7.1.1
  - ◆ Either truck or Lane Load
  - ◆ Truck governs for shorter spans

# Pipe Culverts

## ■ Lane Loads not applied to pipe

- ◆ For top slabs of box culverts of all spans and for all other cases, including slab-type bridges where the span does not exceed 15.0 ft, only the axle loads of the design truck or design tandem of Articles 3.6.1.2.2 and 3.6.1.2.3, respectively, shall be applied.
- ◆ History

# Tire Footprint

- LRFD – 3.6.1.2.6
  - ◆  $w = 20$  in.
  - ◆  $l = 10$  in.
- Standard Specification – 6.4.1
  - ◆ “Concentrated Load”

# Box Under Shallow Fill Distribution Width

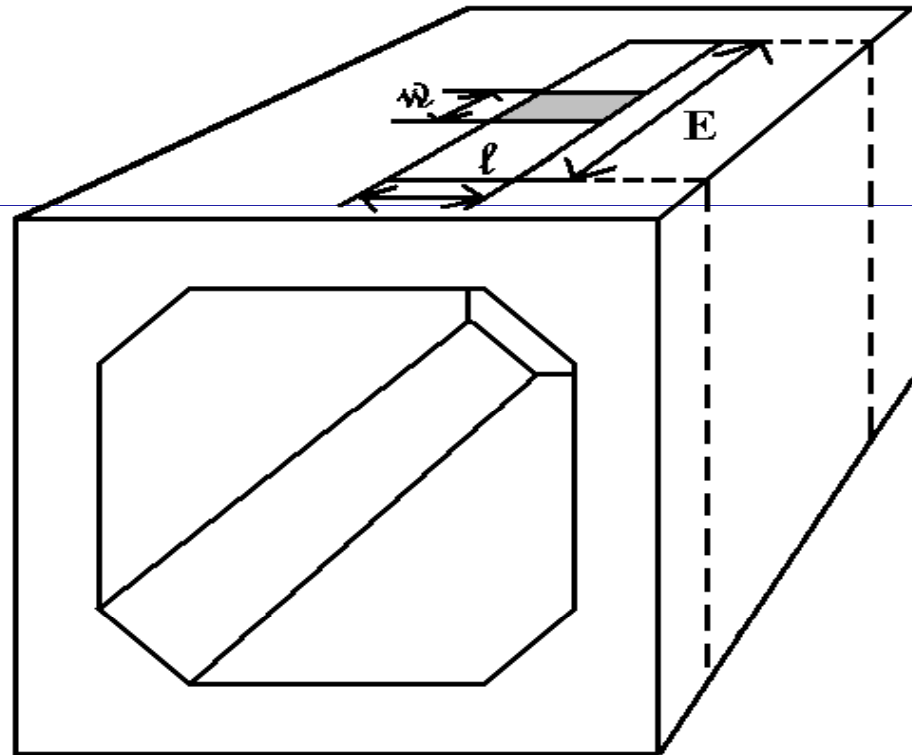

$$E = 96 + 1.44 (s) ;$$

**E in inches, s in feet**

# Distribution Width

- LRFD (4.6.2.10)
  - ◆  $E = 96 + 1.44S$  (for axle)
  - ◆ E in inches and S in feet
- Standard (3.24.3.2)
  - ◆  $E = 4 + 0.06S$  (for wheel)
  - ◆ E in feet and S in feet

# Distribution Steel

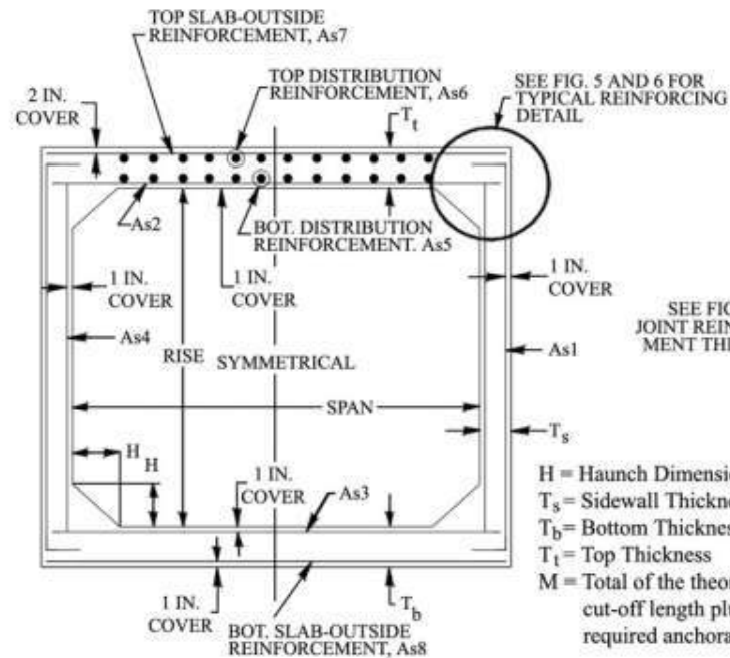

Fill Height Less than 2 ft

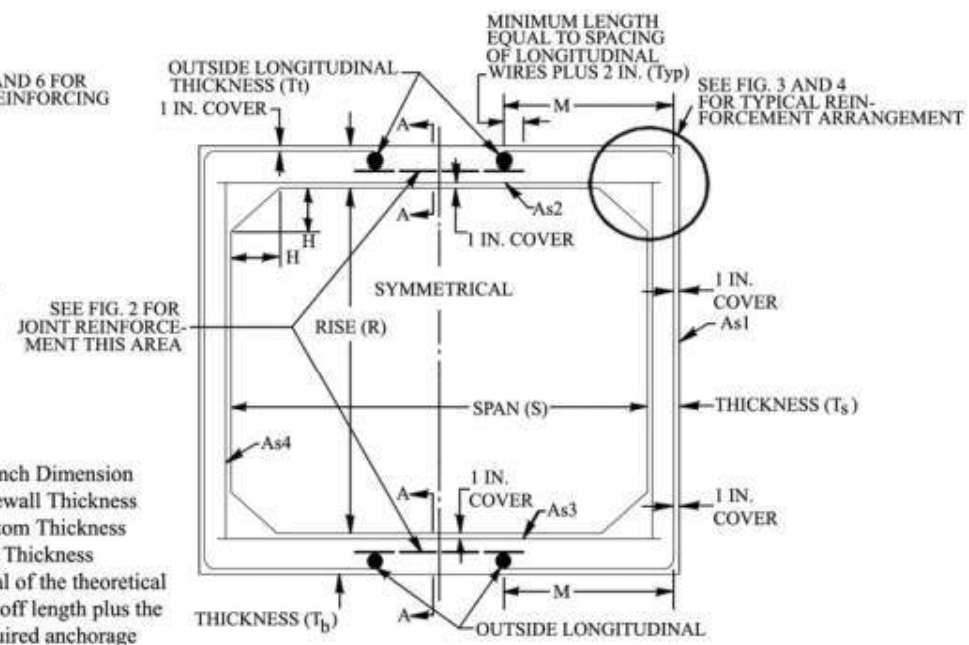

Fill Height 2 ft and Greater

H = Haunch Dimension  
 Ts = Sidewall Thickness  
 Tb = Bottom Thickness  
 Tt = Top Thickness  
 M = Total of the theoretical cut-off length plus the required anchorage

# Live Load Distribution Parallel to Box Culvert Span under Shallow Fill

Parallel to the span:

$$E_{span} = L_T + LLDF(H) \quad (4.6.2.10.2-2)$$

where:

$E$  = equivalent distribution width perpendicular to span (in.)

$S$  = clear span (ft)

$E_{span}$  = equivalent distribution length parallel to span (in.)

# Live Load Distribution

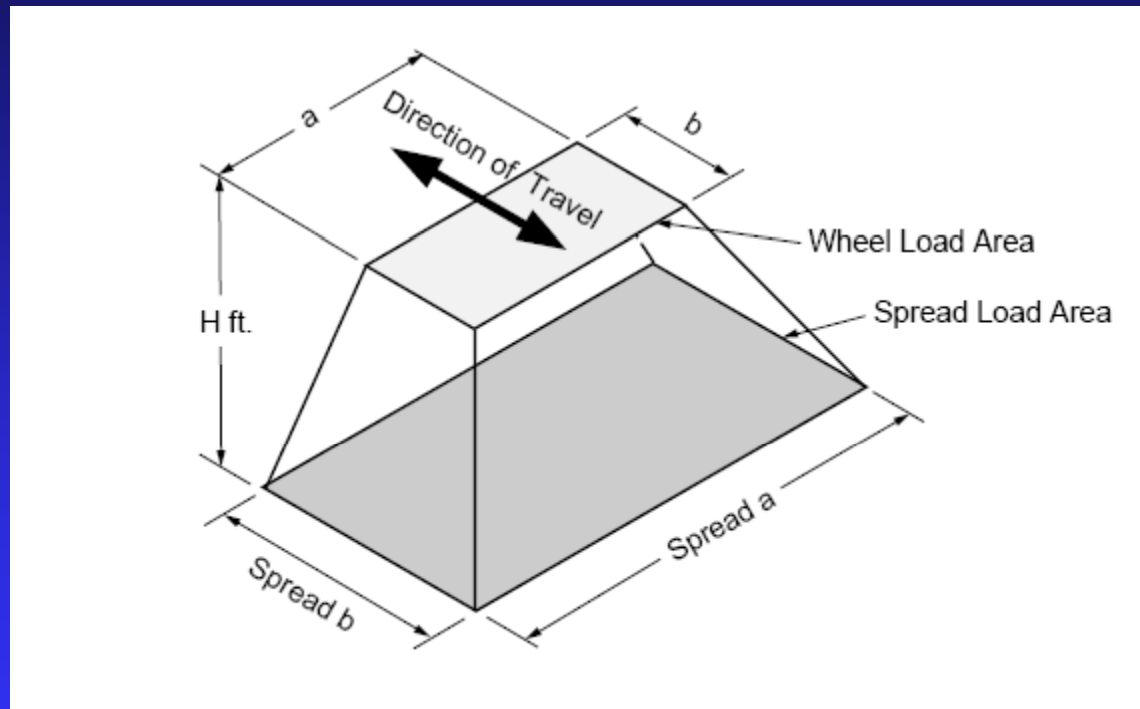

STD – Spread a = a + 1.75\*H

LRFD – Spread a = a + 1.15\*H

STD – Spread b = b + 1.75\*H

LRFD – Spread b = b + 1.15\*H

## Effective Supporting Length of Pipe

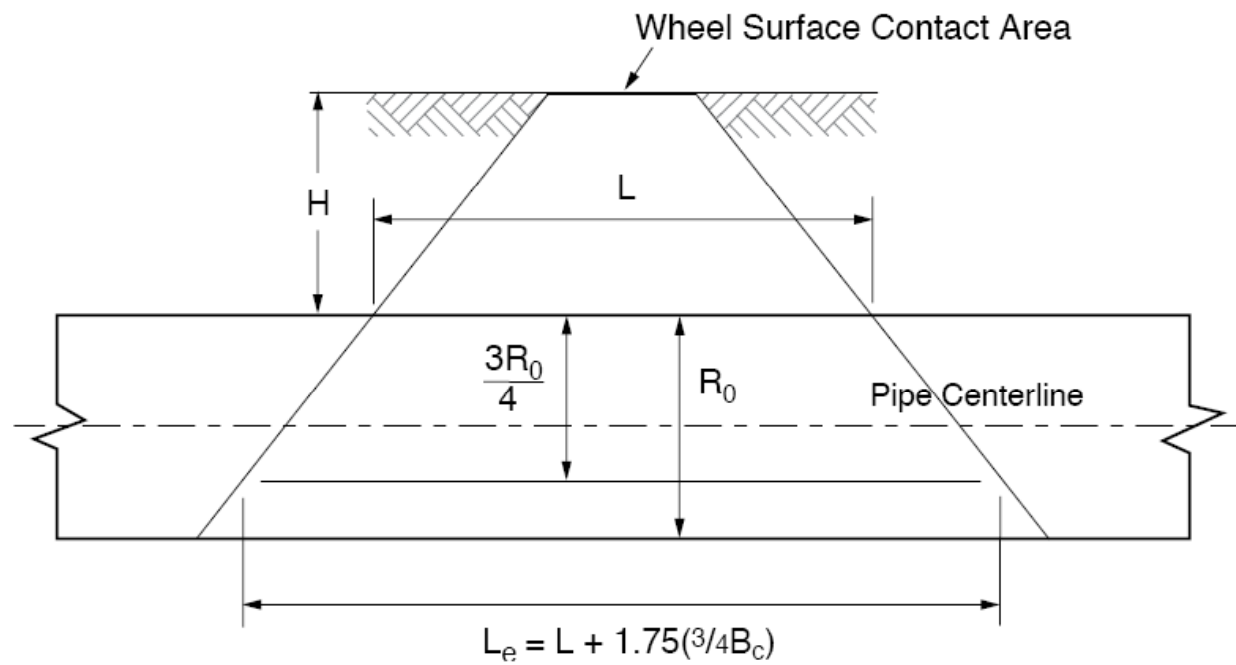

# Pipe Under Shallow Fill

Table 12.10.4.3.2c-1—Bedding Factors,  $B_{FLL}$ , for the Design Truck

Fill Height, ft	Pipe Diameter, in.						
	12	24	36	48	60	72	84
0.5	2.2	1.7	1.4	1.3	1.3	1.1	1.1
1.0	2.2	2.2	1.7	1.5	1.4	1.3	1.3
1.5	2.2	2.2	2.1	1.8	1.5	1.4	1.4
2.0	2.2	2.2	2.2	2.0	1.8	1.5	1.5
2.5	2.2	2.2	2.2	2.2	2.0	1.8	1.7
3.0	2.2	2.2	2.2	2.2	2.2	2.2	1.8
3.5	2.2	2.2	2.2	2.2	2.2	2.2	1.9
4.0	2.2	2.2	2.2	2.2	2.2	2.2	2.1

Table 12.6.6.3-1—Minimum Soil Cover

Type	Condition	Minimum Cover
Corrugated Metal Pipe	—	$S/8 \geq 12.0$ in.
Spiral Rib Metal Pipe	Steel Conduit	$S/4 \geq 12.0$ in.
	Aluminum Conduit where $S \leq 48.0$ in.	$S/2 \geq 12.0$ in.
	Aluminum Conduit where $S > 48.0$ in.	$S/2.75 \geq 24.0$ in.
Structural Plate Pipe Structures	—	$S/8 \geq 12.0$ in.
Long-Span Structural Plate Pipe Structures	—	Refer to Table 12.8.3.1.1-1
Structural Plate Box Structures	—	1.4 ft as specified in Article 12.9.1
Reinforced Concrete Pipe	Unpaved areas and under flexible pavement	$B_c/8$ or $B'_c/8$ , whichever is greater, $\geq 12.0$ in.
	Compacted granular fill under rigid pavement	9.0 in.
Thermoplastic Pipe	—	$ID/8 \geq 12.0$ in.
Deep Corrugated Structural Plate Structures	—	See Article 12.8.9.4



# Live Load Area for Depths $\geq 2$ ft.

## ■ LRFD (3.6.1.2.6)

- ◆  $A_L = (20/12 + 1.15D_E)(10/12 + 1.15D_E)$

- ◆ 1.15 above should be replaced with 1.0 if select granular backfill is not used

## ■ Standard (6.4.1)

- ◆  $A_L = (1.75D_E)^2$

# Live Load Spread

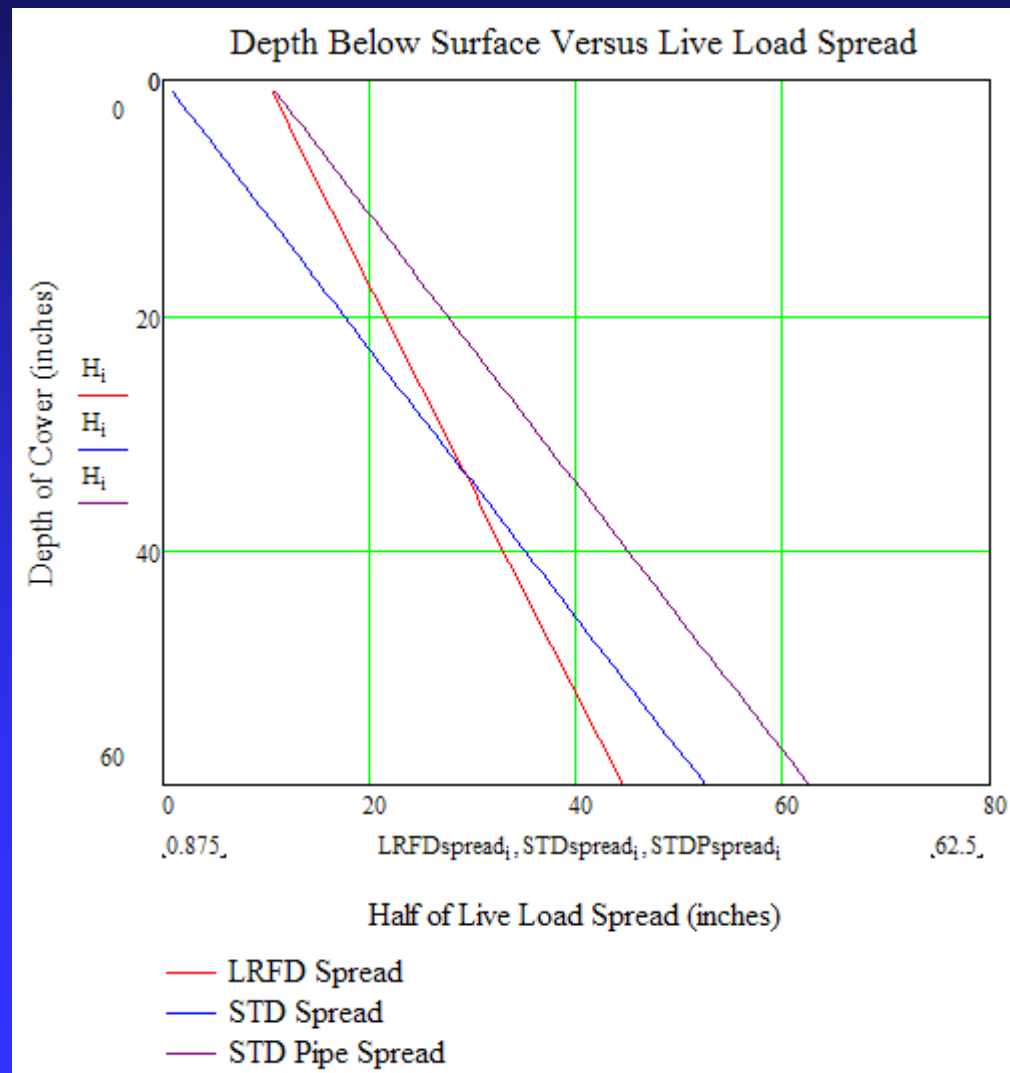

# Dynamic Load Allowance

- LRFD – Dynamic Load Allowance (3.6.2.2)
  - ◆  $DLA = 0.33(1.0 - 0.125D_E)$
- Standard – Impact Factor (3.8.2.3)
  - ◆  $IM = 0.3 - 0'-0''$  to  $1'-0''$  INCL.
  - ◆  $IM = 0.2 - 1'-1''$  to  $2'-0''$  INCL.
  - ◆  $IM = 0.1 - 2'-1''$  to  $2'-11''$  INCL.

# Two Trucks Passing

HS 20 & LRFD Alternate Loads

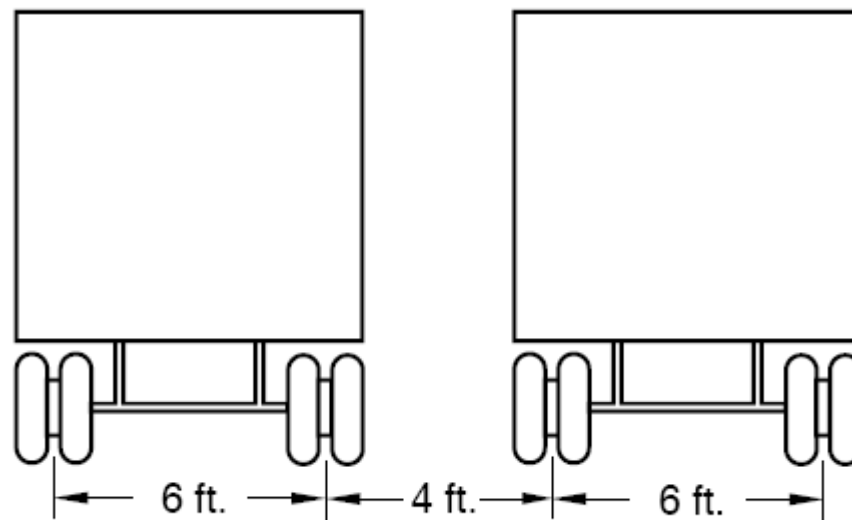

# Live Load Distribution through Pipe and Soil

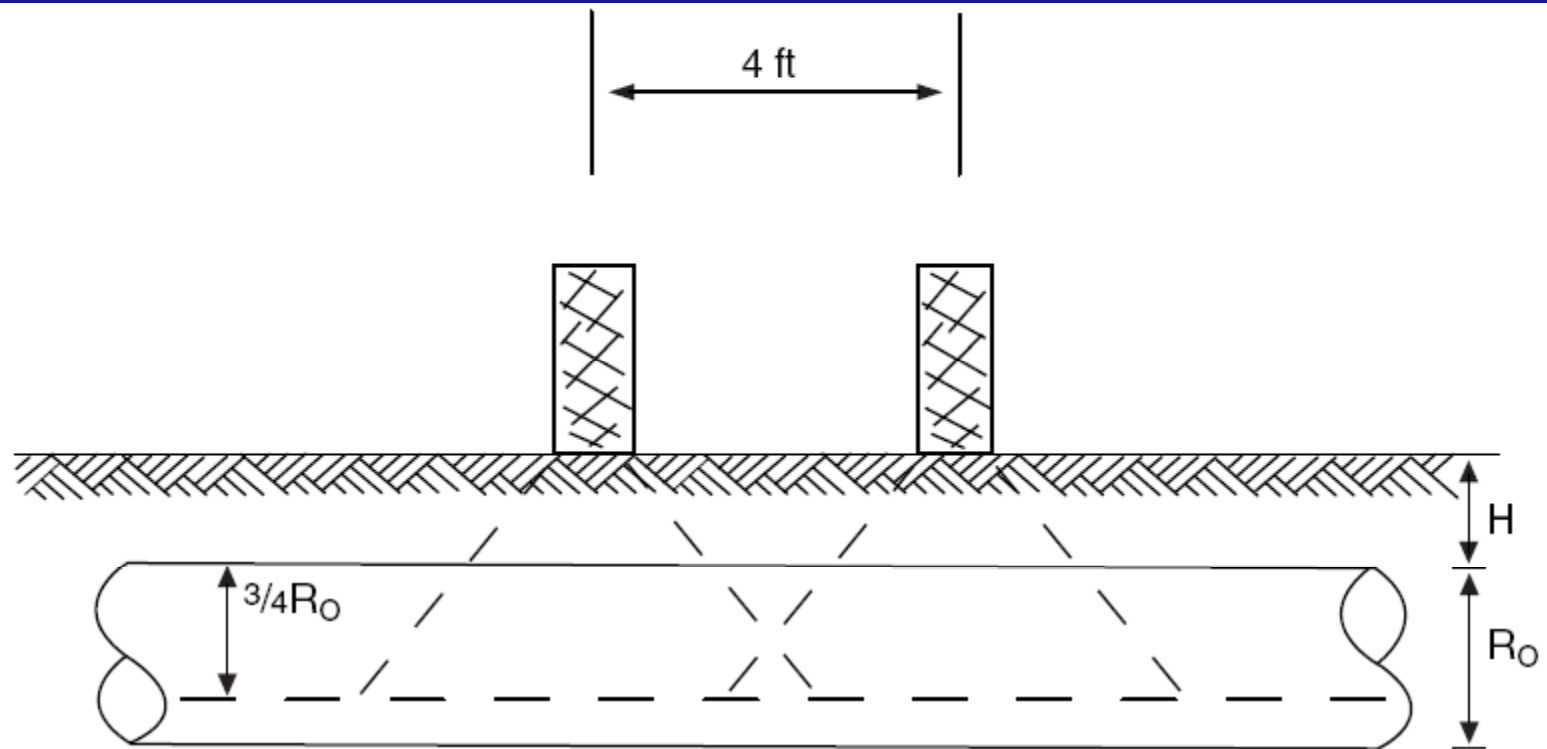

# Multiple Presence Factor

	Design Code		
Lanes	AASHTO STD	AASHTO LRFD	CHBDC
1	1.0	1.2	1.0
2	1.0	1.0	0.90
3	0.90	0.85	0.80
4	0.75	0.65	0.70

# Box Culverts – Shallow Fill

## Design Using Single Lane

### *4.6.2.10.2—Case 1: Traffic Travels Parallel to Span*

When traffic travels primarily parallel to the span, culverts shall be analyzed for a single loaded lane with the single lane multiple presence factor.

# Soil Load

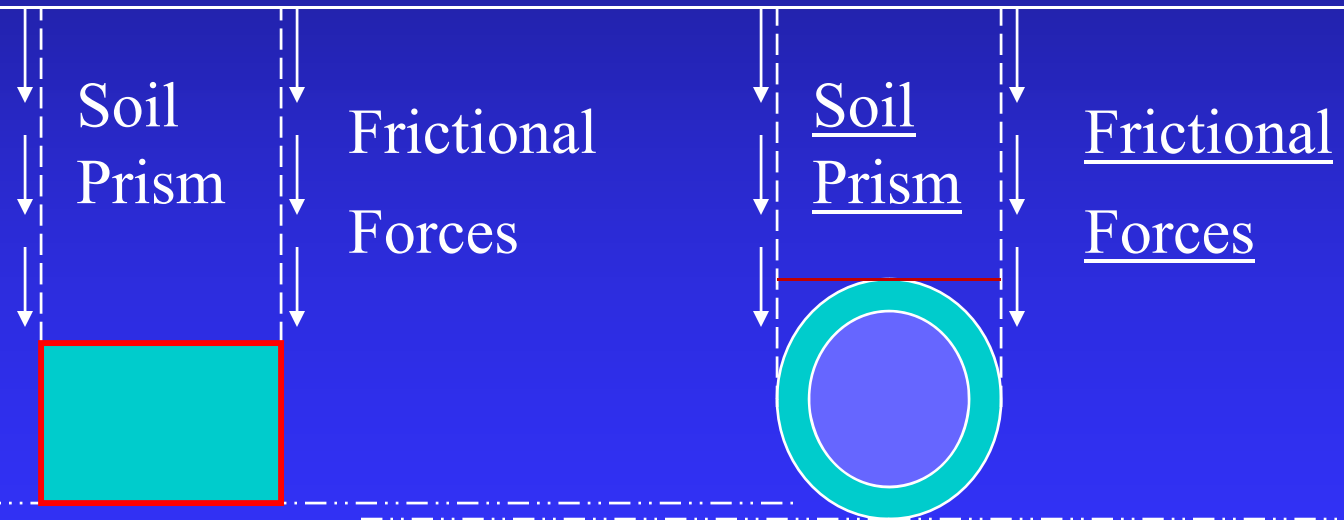

Natural Ground

Natural Ground

# Soil Load

- $W_E = F_e \gamma_s B_c H$ 
  - ◆ Boxes – Section 12.11.2.2.1
  - ◆ Pipe – Section 12.10.2.1

# Soil-Structure Interaction Factor

## Boxes

- $W_E = F_e \gamma_s B_c H$ 
  - ◆  $F_e = 1 + 0.20(H/B_c)$
  - ◆  $F_e$  shall not exceed 1.15 for installations with compacted fill along the sides of the box section, or 1.40 for installations with uncompacted fill

# Soil-Structure Interaction Factor Pipe

- “Standard installations for both embankments and trenches shall be designed for positive projection, embankment loading conditions where  $F_e$  shall be taken as the vertical arching factor, VAF, specified in Table 12.10.2.1-3 for each type of standard installation.”

# AASHTO LRFD 12.10.2.1

Table 12.10.2.1-3 Coefficients for use with Figure 1.

	Installation Type			
	1	2	3	4
<i>VAF</i>	1.35	1.40	1.40	1.45
<i>HAF</i>	0.45	0.40	0.37	0.30
<i>A1</i>	0.62	0.85	1.05	1.45
<i>A2</i>	0.73	0.55	0.35	0.00
<i>A3</i>	1.35	1.40	1.40	1.45
<i>A4</i>	0.19	0.15	0.10	0.00
<i>A5</i>	0.08	0.08	0.10	0.11
<i>A6</i>	0.18	0.17	0.17	0.19
<i>a</i>	1.40	1.45	1.45	1.45
<i>b</i>	0.40	0.40	0.36	0.30
<i>c</i>	0.18	0.19	0.20	0.25
<i>e</i>	0.08	0.10	0.12	0.00
<i>f</i>	0.05	0.05	0.05	—
<i>u</i>	0.80	0.82	0.85	0.90
<i>v</i>	0.80	0.70	0.60	—

# Vertical Pressures and Reactions

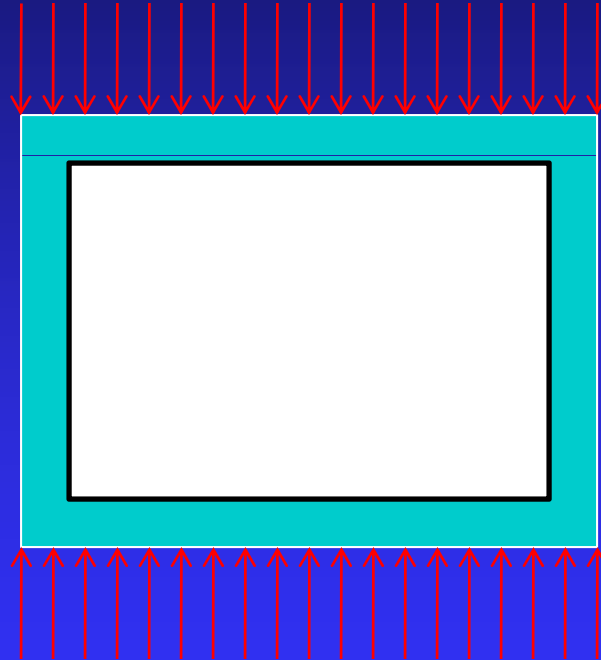

# Vertical Soil Load

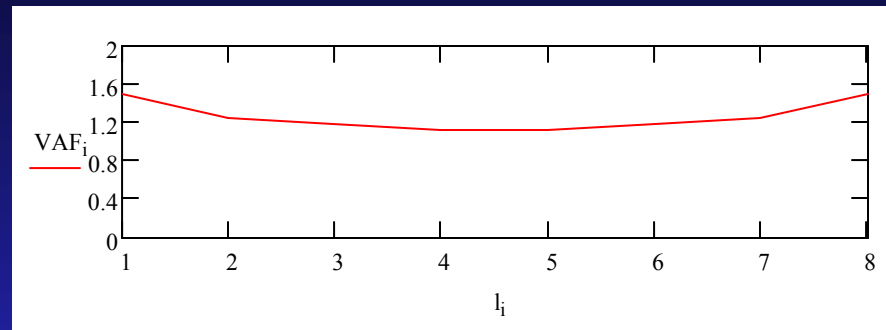

“Bedding and Fill Heights for Concrete Roadway Pipe And Box Culverts” – C. Yoo, F. Parker, and J. Kang, Auburn University, June 2005

# Bottom Reaction to Vertical Loads

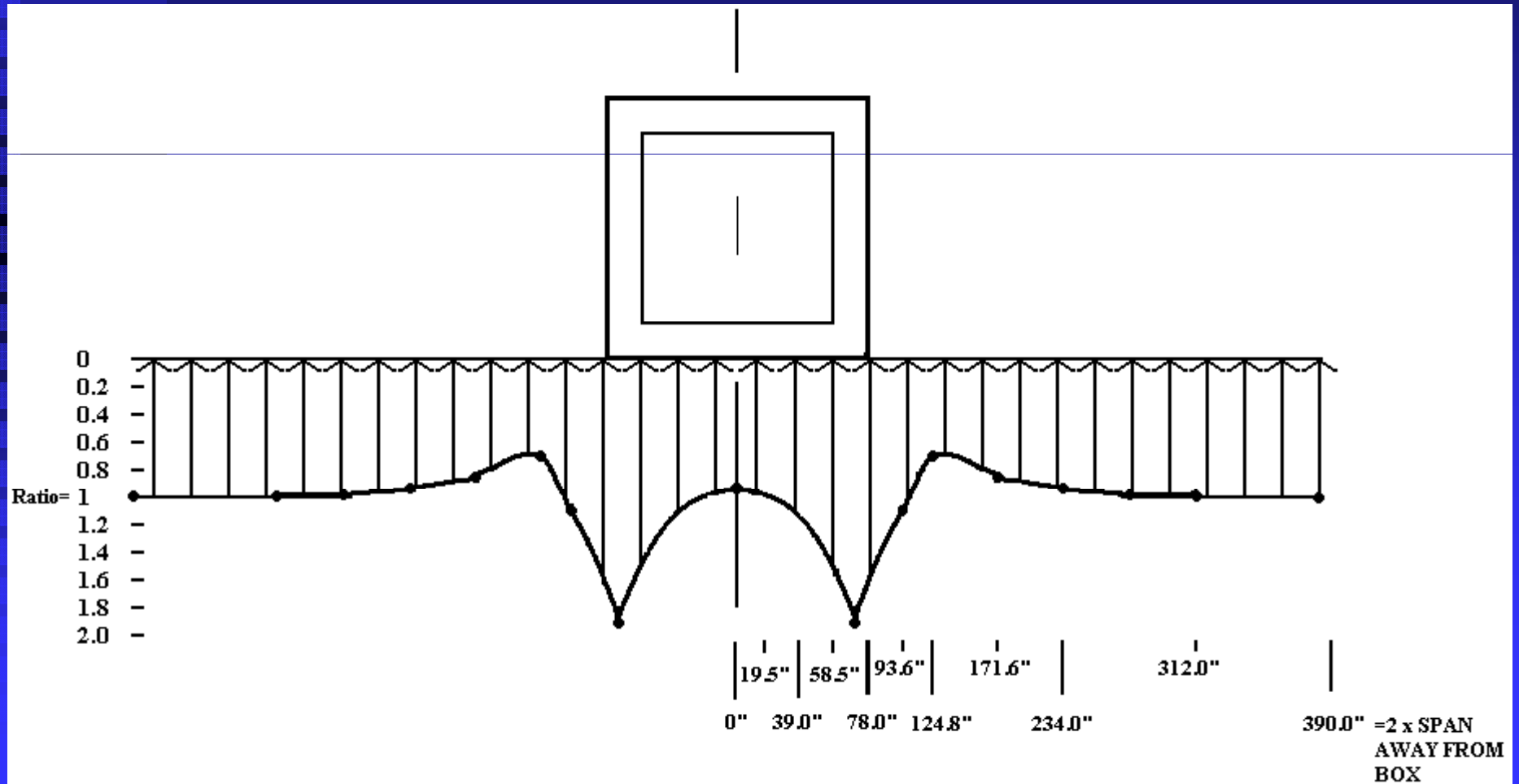

## LRFD (C12.11.2.3)

- “While typical designs assume a uniform pressure distribution across the bottom slab, a refined analysis that considers the actual soil stiffness under box sections will result in pressure distributions that reduce bottom slab shear and moment forces (McGrath et al. 2004.)”

## LRFD C12.11.2.3

- “Such an analysis requires knowledge of in-situ soil properties to select the appropriate stiffness for the supporting soil. A refined analysis taking this into account may be beneficial when analyzing existing culverts.”

# Pipe Pressure Distribution

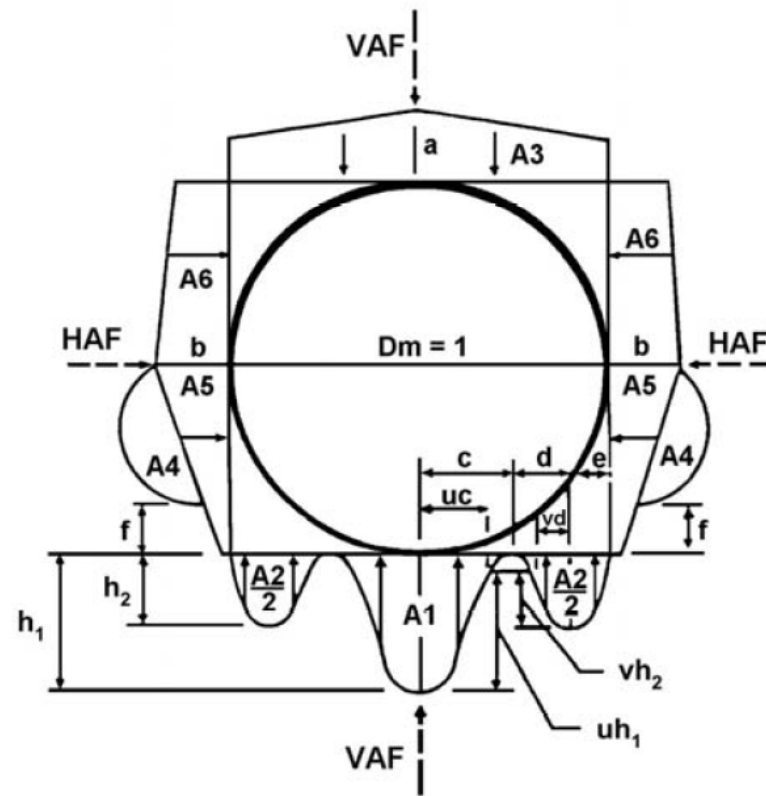

Figure 12.10.2.1-1—Heger Pressure Distribution and Arching Factors

# Lateral Live Load

## ■ LRFD (3.11.6.2)

- ◆ “The horizontal pressure  $\Delta_{ph}$  in ksf, on a wall resulting from a point load may be taken as:”

$$\Delta_{ph} = \frac{P}{\pi R^2} \left[ \frac{3ZX^2}{R^3} - \frac{R(1-2\nu)}{R+Z} \right]$$

# Boussinesq Distribution

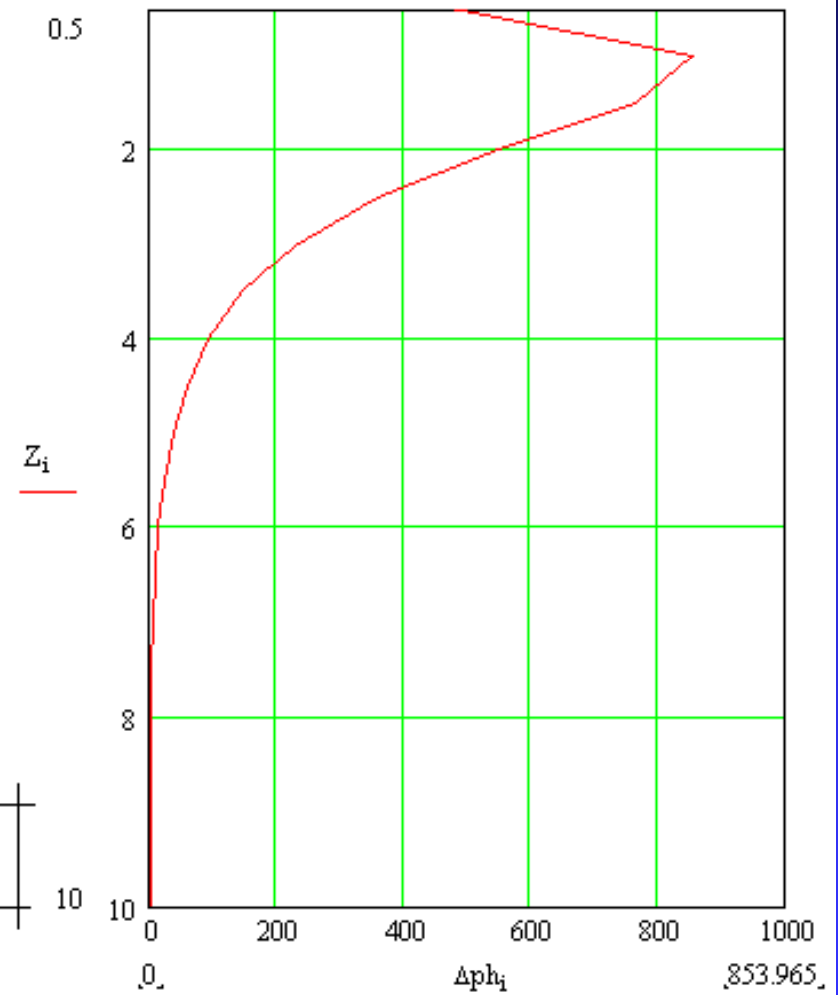
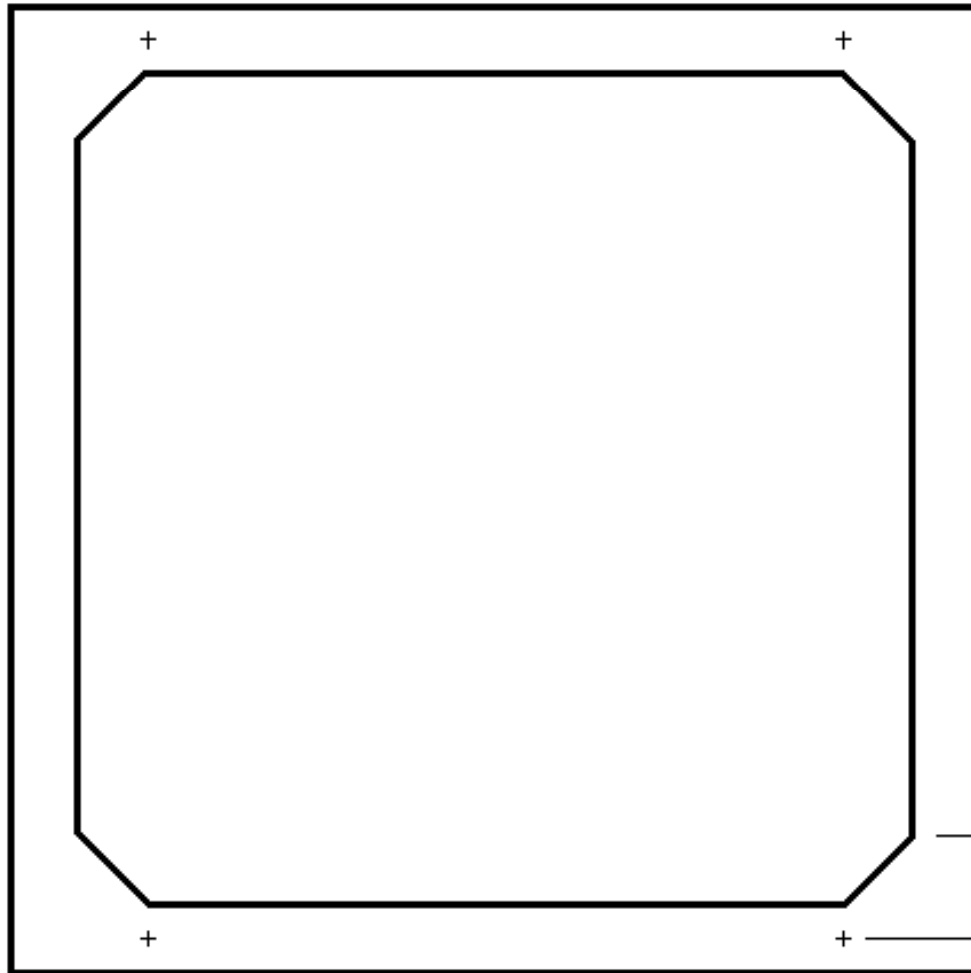

# Live Load Lateral Uniform Pressure

- LRFD – 3.11.6.4

- $\Delta_p = K \gamma_s h_{eq}$

- ◆  $H \leq 5 \text{ ft} - h_{eq} = 4 \text{ ft}$

- ◆  $H \leq 10 \text{ ft} - h_{eq} = 3 \text{ ft}$

- ◆  $H \leq 20 \text{ ft} - h_{eq} = 2 \text{ ft}$

# Lateral Uniform Live Load

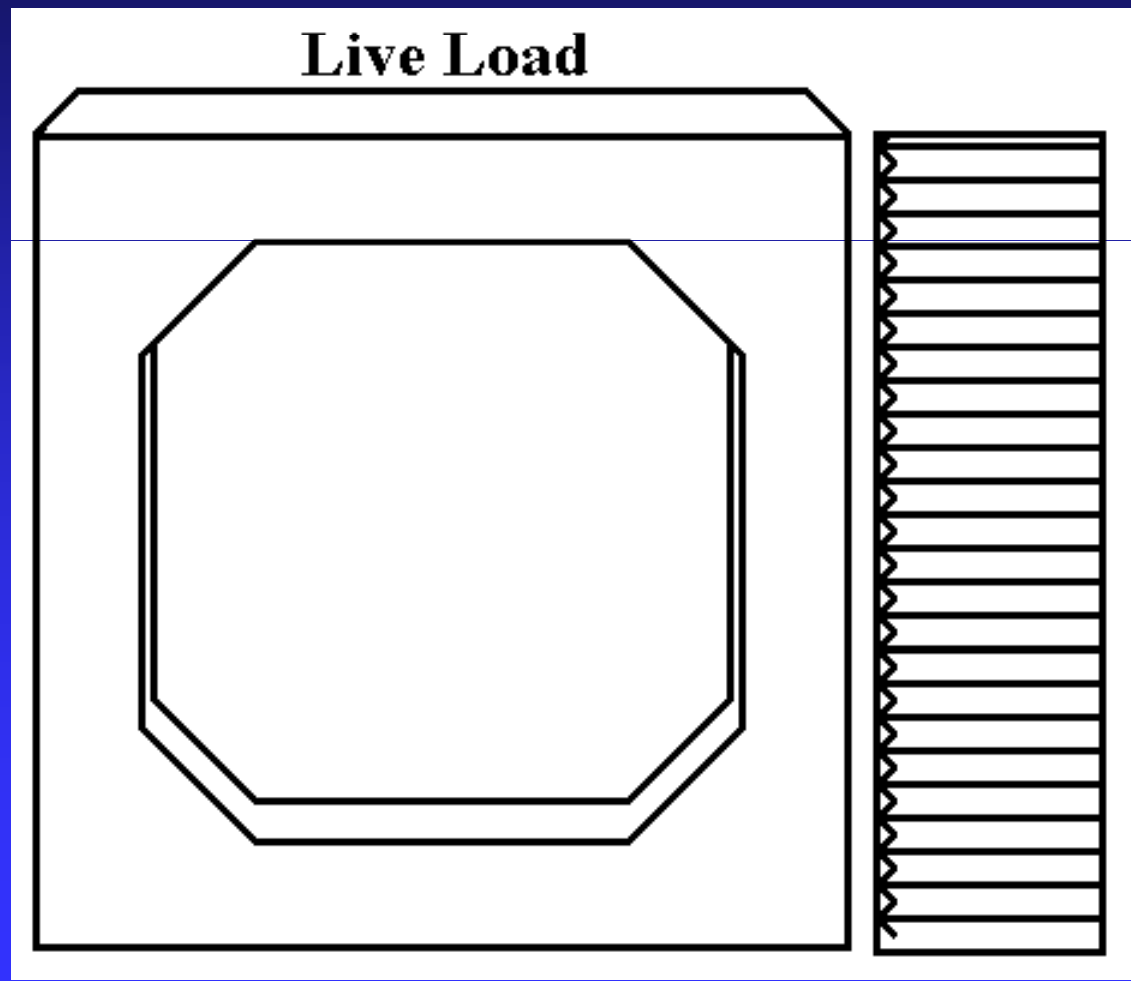

“In general, LRFD produces greater live load surcharge pressures than Standard for depths of fill of 5 ft or less and less pressure for greater depths. In addition, live load surcharge pressures from AASHTO M 259 and M 273 are much greater than those from LRFD for depths of fill from 0 to 1 ft and less than LRFD for greater fill heights. In spite of the significant differences in live load surcharge pressures, their impact on reinforcement areas is relatively minor”

“Comparison of AASHTO Standard and LRFD Code Provisions for Buried Concrete Box Culverts” – R. Rund & T. McGrath, STP 1368, 2000, Concrete Pipe for the New Millenium

# Lateral Earth Pressure

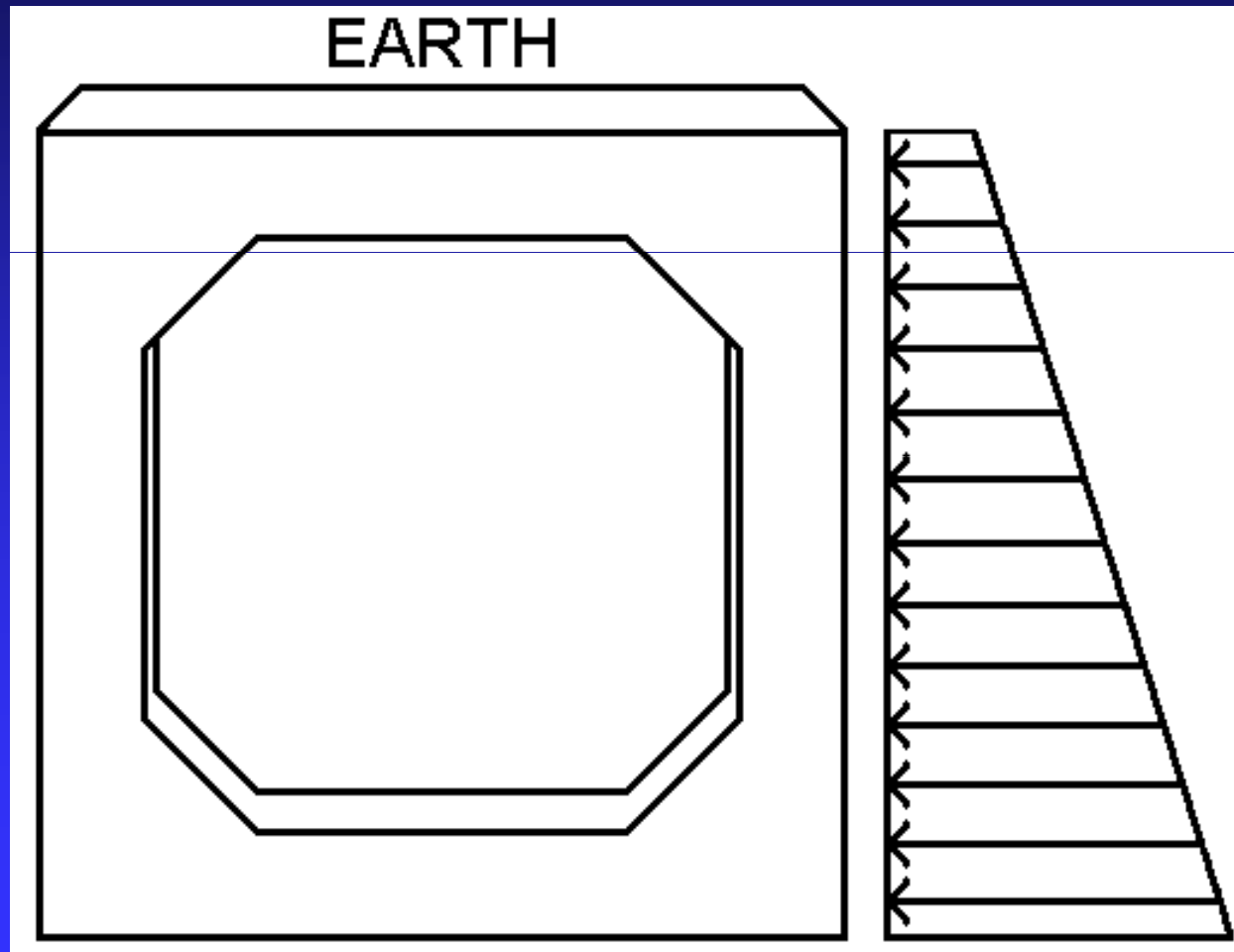

# Lateral Earth Load - LRFD

- 3.11.5.5 – Equivalent Fluid Method
  - ◆ Loose Sand or Gravel = 55 pcf
  - ◆ Dense Sand or Gravel = 45 pcf
- 3.11.5.2 – At Rest Pressure
  - ◆  $k_o = 1 - \sin\phi$ 
    - ◆  $\phi = 30^\circ$ ,  $k_o = 0.5$ , press = 60 pcf

# Other Loads

- Always Considered
  - ◆ Self Weight
  - ◆ Internal Fluid Load
- Sometimes Considered
  - ◆ Construction Loads
  - ◆ External Hydrostatic Loads
  - ◆ Internal Fluid Pressure

# Load Factors

# Load Factors

Load	Load Factor		
	Standard	LRFD	
		Minimum	Maximum
Dead	1.3	0.90	1.25
Water	1.3	1.0	1.0
Earth – Vertical	1.3	0.90	1.30
Earth - Horizontal	1.3	0.90*	1.35
Live	$1.3 \times 1.67 = 2.17$	0.0	1.75**

\*Per 3.11.7, a 50% reduction in load may be used in lieu of the minimum load factor.

\*\*A multiple presence factor is included in the total load.

# LRFD Design

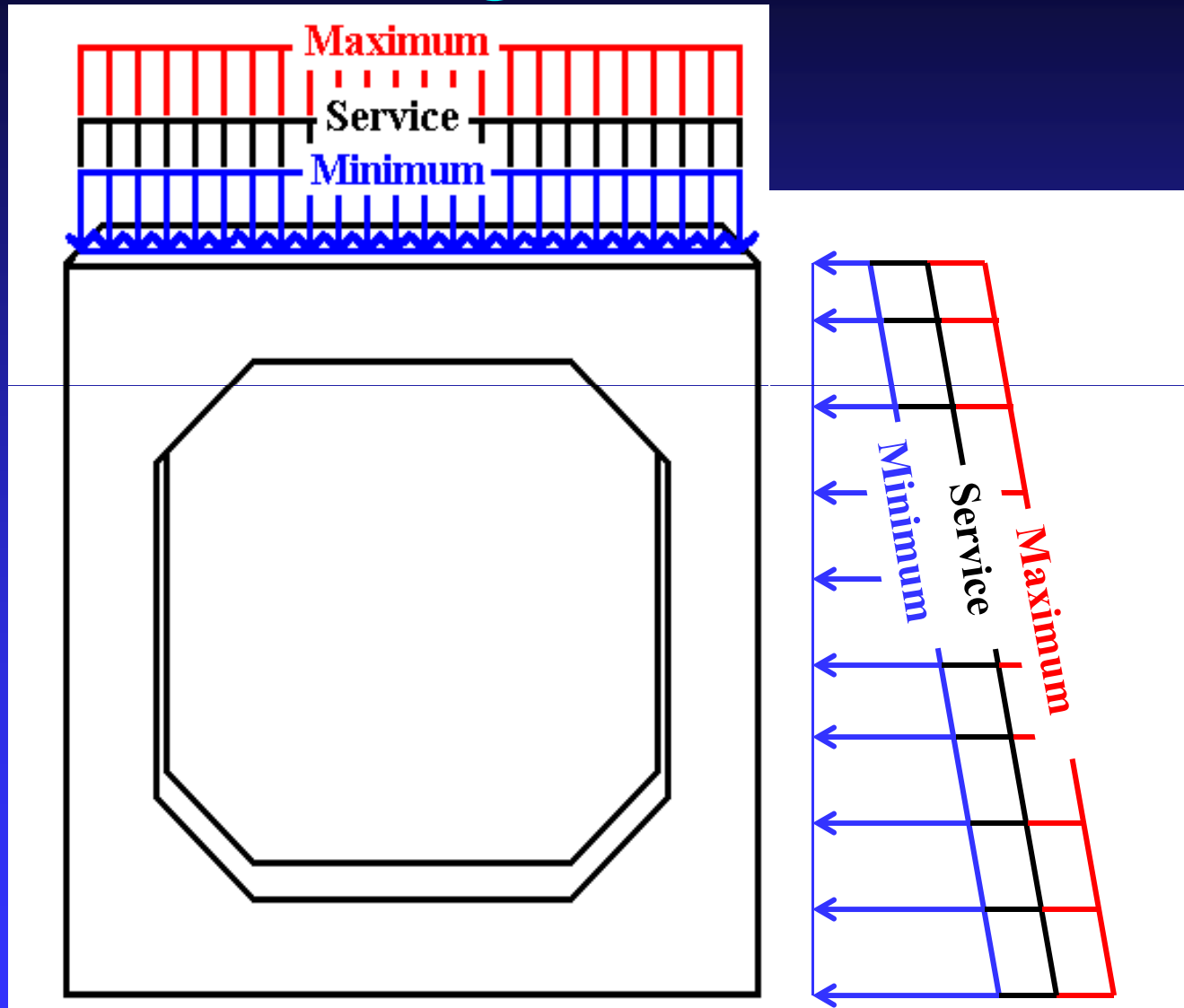

# Phi Factors

## ■ Strength Reduction Factors

- ◆  $\phi_f = 1.0$
- ◆  $\phi_v = 0.9$
- ◆ LRFD – 12.5.5-1
- ◆ Standard – 16.7.4.6



# “Basis of LRFD Methodology”

■  $\sum \eta_i \gamma_i Q_i \leq \phi R_n$

- ◆  $\gamma_i$  = a statistically based load factor
- ◆  $\phi$  = a statistically based resistance factor
- ◆  $Q_i$  = force effect
- ◆  $R_n$  = nominal resistance
- ◆  $\eta_i$  = load modifier relating to ductility, redundancy, and operational importance

# Load Modifier - Culverts

- LRFD 12.5.4

- ◆ “Load modifiers shall be applied to buried structures and tunnel liners as specified in Article 1.3, except that the load modifiers for construction loads shall be taken as 1.0”

# Load Modifiers

- LRFD C 1.3.2.1

- ◆ “Ductility, redundancy, and operational importance are significant aspects affecting the margin of safety of bridges.”

# Load Modifiers (LRFD) For Culverts

- Standard = N/A
- LRFD (1.3.2)
  - ◆ Ductility =  $\eta_D = 1.0$
  - ◆ Redundancy =  $\eta_R = 1.05$  or  $1.0$
  - ◆ Importance =  $\eta_I = 1.0$  or  $1.05$

# Load Modifier Culverts

- LRFD 1.3.3 – Ductility

- ◆ “The structural system of a bridge shall be proportioned and detailed to ensure the development of significant and visible inelastic deformations at the strength and extreme event limit states before failure.”

# Load Modifier - Culverts

- LRFD 12.5.4 - Redundancy

- ◆ “For strength limit states, buried structures shall be considered nonredundant (1.05) under earth fill and redundant (1.0) under live load and dynamic load allowance.”

# Load Modifier - Culverts

- LRFD 12.5.4 - Importance

- ◆ “Operational importance shall be determined on the basis of continued function and/or safety of the roadway.”



# Design Capacity

# Design for:

- Flexure
  - ◆ Steel Reinforcement
  - ◆ Concrete Compression
- Crack Control
- Shear
- Radial Tension (for pipe only)
- Fatigue (not required for box culverts or pipe per LRFD)

# Box Culverts and Pipe

- Section 12.10 – Reinforced Concrete Pipe
  - ◆ Section 12.10.4.2 – Direct Design –  $A_s = ?$
  - ◆ Section 12.10.4.3 – Indirect Design – Class = ?
- Section 12.11 - Precast Box Culverts

# Flexure

$$A_{si} = \frac{g \cdot \phi_f \cdot d - Nu - \sqrt{g \cdot [g \cdot (\phi_f \cdot d)^2 - Nu \cdot (2 \cdot \phi_f \cdot d - t) - 2 \cdot Mu]}}{f_y}$$

Equation 12.10.4.2.4a-1 – For Direct Design of Pipe

Section 5.7.2 – Assumptions for Strength and Extreme Event Limit States takes a broader view of flexural design

# Flexure (Minimum Steel)

LRFD - 12.11.4.3.2: STD - 16.7.4.8

- $A_{s_{min}} = 0.002 b h$ 
  - ◆  $b = 12$  inch unit width
  - ◆  $h =$  thickness of member in inches
- LRFD (12.11.4.3.2)
- Standard (16.7.4.8)

# ACI 318-08

7.12.2.1 — Area of shrinkage and temperature reinforcement shall provide at least the following ratios of reinforcement area to gross concrete area, but not less than 0.0014:

- (a) Slabs where Grade 40 or 50 deformed bars are used ..... 0.0020
- (b) Slabs where Grade 60 deformed bars or welded wire reinforcement are used ..... 0.0018
- (c) Slabs where reinforcement with yield stress exceeding 60,000 psi measured at a yield strain of 0.35 percent is used .....  $\frac{0.0018 \times 60,000}{f_y}$



# Flexure (maximum steel)

- Box culvert walls and slabs are designed as tension controlled members, with a maximum steel area of 75% of the balanced condition (steel will always yield before concrete crushes)
- Compression controlled design is allowed with other concrete structures as long as a modified phi factor is applied.

# Tension Controlled - Ductile



## Crack Control (LRFD – 5.7.3.4)

$$s \leq \frac{700 \cdot \gamma_e}{\beta_s \cdot f_s} - 2 \cdot d_c$$

- LRFD Concerns itself with steel spacing
- Standard Specification concerns itself with stress in the steel (maximum of 0.6  $f_y$ ?)

# Service Load Stress

$$f_s = \frac{M_s + N_s \cdot \left( d - \frac{h}{2} \right)}{A_s \cdot j \cdot i \cdot d}$$

Equation C12.11.3-1

# Factors affecting crack control

$$\beta_s = 1 + \frac{d_c}{0.7(h - d_c)}$$

where:

- $\gamma_e$  = exposure factor
- = 1.00 for Class 1 exposure condition
- = 0.75 for Class 2 exposure condition

# Exposure Conditions

Class 1 exposure condition applies when cracks can be tolerated due to reduced concerns of appearance and/or corrosion. Class 2 exposure condition applies to transverse design of segmental concrete box girders for any loads applied prior to attaining full nominal concrete strength and when there is increased concern of appearance and/or corrosion.

**SHEAR**

# Shear

LRFD – 5.14.5.3: STD – 8.16.6.7

Slabs under 2 feet or more of fill

$$V_c = \left( 0.0676 \cdot \sqrt{f_c} + 4.6 \cdot \frac{A_s}{b \cdot d_e} \cdot \frac{V_u \cdot d_e}{M_u} \right) \cdot b \cdot d_e$$

Need not be taken less than

$$V_c = 0.0948 \cdot \sqrt{f_c} \cdot b \cdot d_e$$

Equivalent to  $\beta = 3$

# Shear

LRFD – 5.8.3.3: STD – 8.16.6.2.1

Slabs with less than two feet of cover,  
and sidewalls

$$V_c = 0.0316 \cdot \beta \cdot \sqrt{f'_c} \cdot b_v \cdot d_v$$

$\beta$  is based on the dimensions of the element and the strain in the steel

# Shear

## LRFD – 5.8.3.3: STD – 8.16.6.2.1

### Slabs with less than two feet of cover, and sidewalls

When sections do not contain at least the minimum amount of shear reinforcement, the value of  $\beta$  may be as specified in Eq. 5.8.3.4.2-2:

$$\beta = \frac{4.8}{(1 + 750\varepsilon_s)} \frac{51}{(39 + s_{xe})} \quad (5.8.3.4.2-2)$$

$$\varepsilon_s = \frac{\left( \frac{|M_u|}{d_v} + 0.5N_u + |V_u - V_p| - A_{ps}f_{po} \right)}{E_s A_s + E_p A_{ps}} \quad (5.8.3.4.2-4)$$

For sections with an overall depth less than 16 inches, and no tension,  $\beta$  can be assumed equal to 2

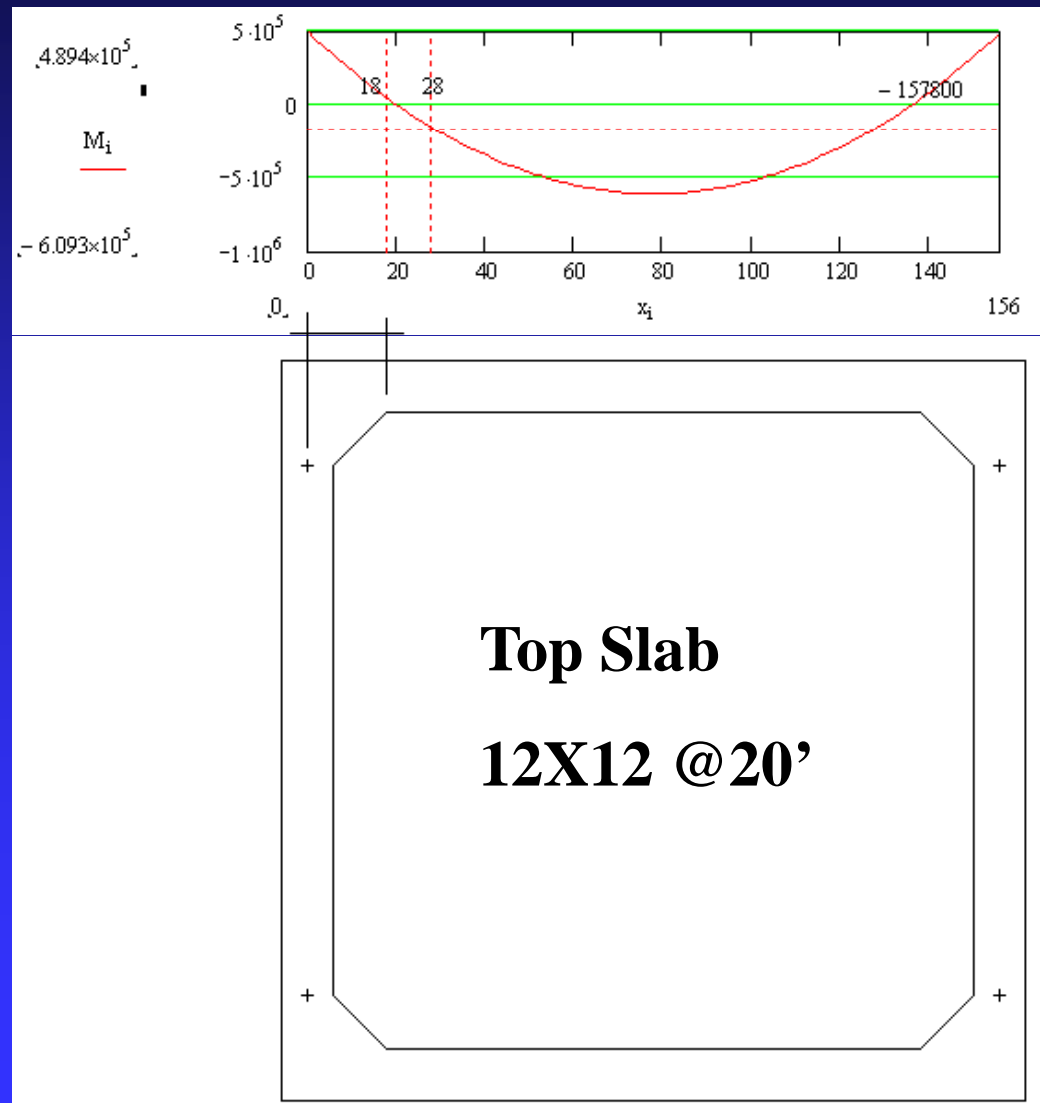

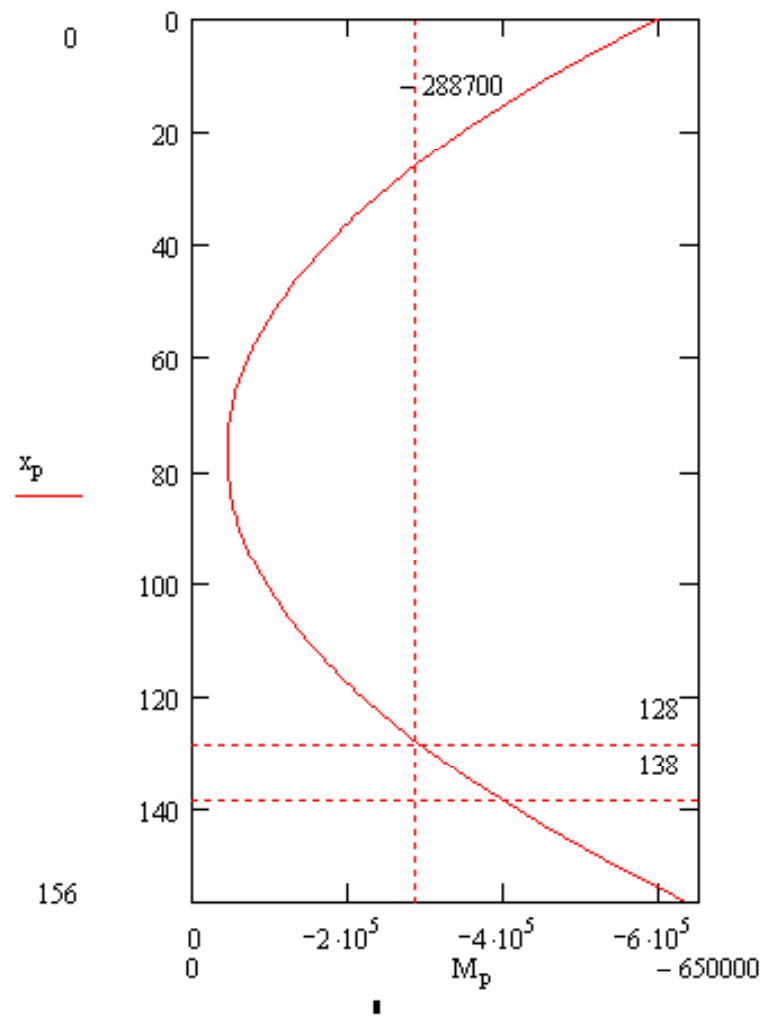
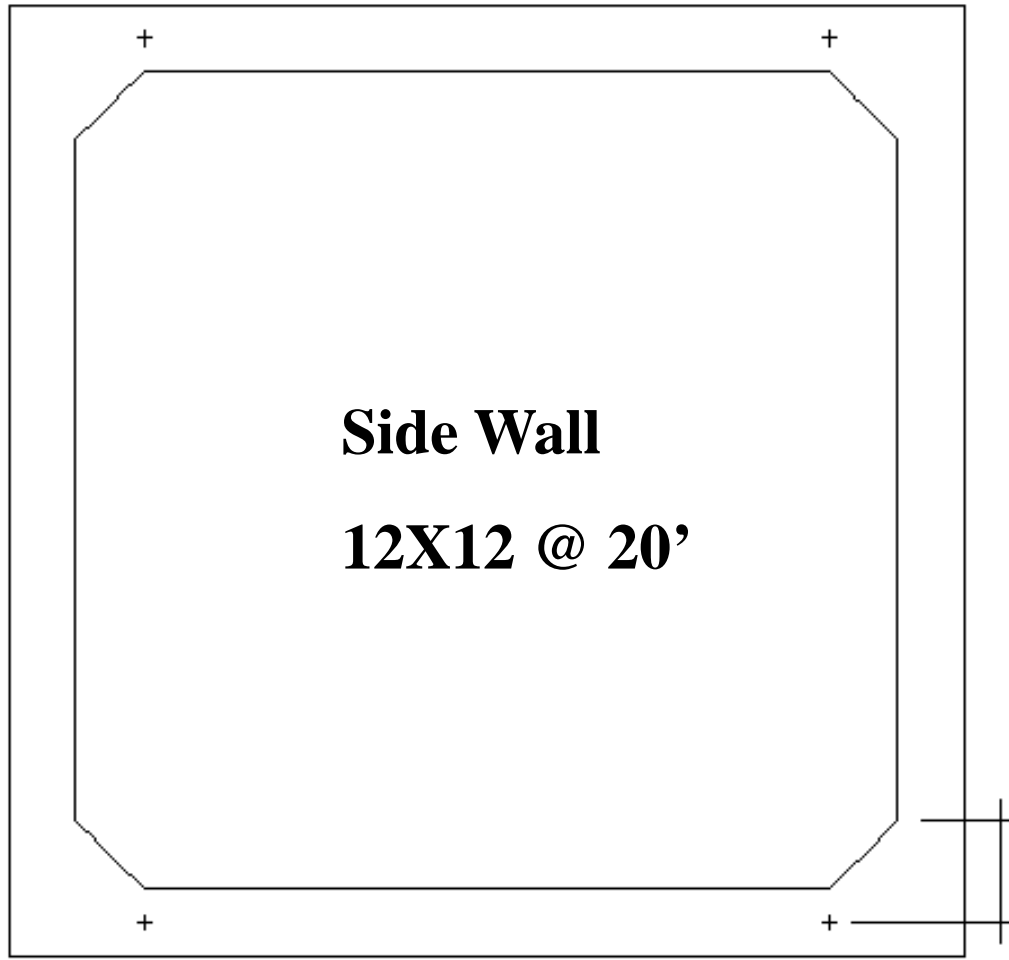

# Distribution Steel

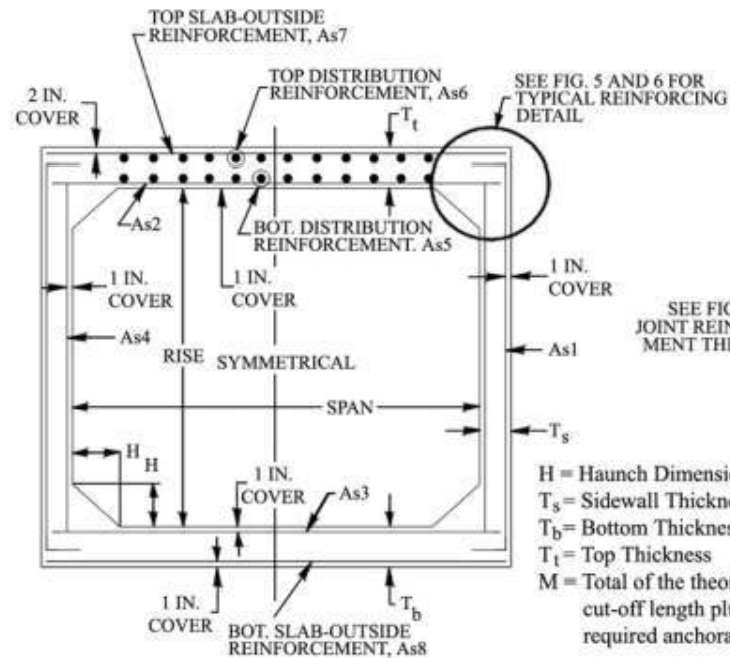

Fill Height Less than 2 ft

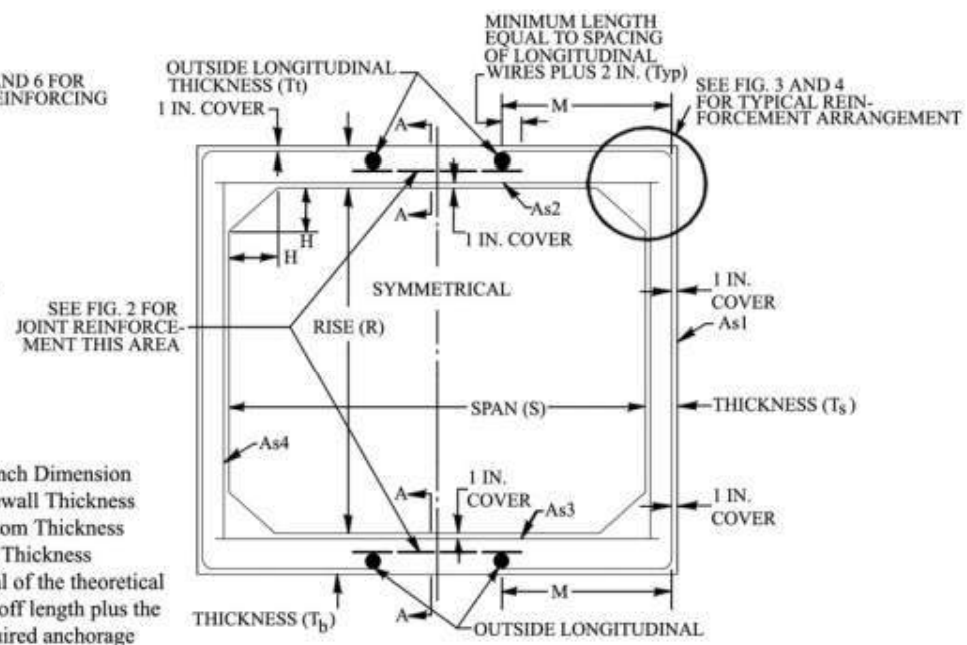

Fill Height 2 ft and Greater

H = Haunch Dimension  
 Ts = Sidewall Thickness  
 Tb = Bottom Thickness  
 Tt = Top Thickness  
 M = Total of the theoretical cut-off length plus the required anchorage

# Distribution Steel

- In bottom of top slab (LRFD 9.7.3.2)
  - ◆ Percentage of main positive moment reinforcement =  $100/S^{1/2}$
  - ◆  $S$  = span in feet
  - ◆ Need not be more than 50 percent
- In top of top slab
  - ◆  $A_{s_6} = 0.002 \times A_g$

# CONCRETE PIPE DESIGN

# Concrete Pipe Indirect Design – 12.10.4.3

## D-Load Equation

$$D = \left( \frac{12}{S_i} \right) \left( \frac{W_E + W_F}{B_{FE}} + \frac{W_L}{B_{FLL}} \right) \quad (12.10.4.3.1-1)$$

where:

$B_{FE}$  = earth load bedding factor specified in Article 12.10.4.3.2a or Article 12.10.4.3.2b

$B_{FLL}$  = live load bedding factor specified in Article 12.10.4.3.2c

$S_i$  = internal diameter of pipe (in.)

$W_E$  = total unfactored earth load specified in Article 12.10.2.1 (kip/ft)

$W_F$  = total unfactored fluid load in the pipe as specified in Article 12.10.2.2 (kip/ft)

$W_L$  = total unfactored live load on unit length pipe specified in Article 12.10.2.3 (kip/ft)



## Highway Live Loads on Concrete Pipe

### FOREWORD

Thick, high-strength pavements designed for heavy truck traffic substantially reduce the pressure transmitted through a wheel to the subgrade and, consequently, to the underlying concrete pipe. The pressure reduction is so great that generally the live load can be neglected. In 1926, Westergaard presented a paper summarizing the results of an extensive study of the effects of loading conditions, subgrade support, and boundary conditions on concrete pavements<sup>(1)</sup>. These results formed the basis by which Westergaard developed a method to calculate the stresses in concrete slabs. Based upon the work of Westergaard and others, the Portland Cement Association, (PCA), developed a method to determine the vertical pressure on buried pipe due to wheel loads applied to concrete pavements<sup>(2)</sup>. The PCA method is presented in the American Concrete Pipe Association, ACPA, "Concrete Pipe Handbook"<sup>(3)</sup> and "Concrete Pipe Design Manual"<sup>(4)</sup>.

Intermediate and thin thicknesses of asphalt or flexible pavements do not reduce the pressure transmitted from a wheel to the pavement subgrade to any significant degree. For these pavements, there is no generally accepted theory for estimating load distribution effects, and, therefore, these pavements should be considered as unsurfaced roadways.

Design of Highway Loads in the US often follows the American Association of State Highway and Transportation Officials, AASHTO, criteria. The AASHTO LRFD Bridge Design Specifications specifies the applicable highway loads and their distribution through the soil.

This Design Data addresses the method of determining the live load pressure transmitted through unsurfaced roadways to circular, elliptical and arch concrete pipe in accordance with the criteria of the AASHTO LRFD Bridge Design Specifications.

### INTRODUCTION

To determine the required supporting strength of concrete pipe installed under intermediate and thin thicknesses of asphalt or flexible pavements, or relatively shallow earth cover, it is necessary to evaluate the effect of live loads, such as highway truck loads, in addition to dead loads imposed by the soil and surcharge loads.

### LIVE LOADS

If a rigid pavement or a thick flexible pavement designed for heavy duty traffic is provided with a sufficient buffer between the pipe and pavement, then the live load transmitted through the pavement to the buried concrete pipe is usually negligible at any depth. If any culvert or sewer pipe is within the heavy duty traffic highway right-of-way, but not under the pavement structure, then such pipe should be analyzed for the effect of live load transmission from an unsurfaced roadway, because of the possibility of trucks leaving the pavement.

### DEAD LOADS

Various methods for analyzing soil dead loads, which have been developed over the years, are presented in the ACPA "Concrete Pipe Technology Handbook"<sup>(7)</sup>.

### SURCHARGE LOADS

A common type of surcharge load is additional soil fill placed after the pipe has been installed for a period of time. If the surcharge load is a building or other surface load, the resultant uniformly distributed load can be converted to an equivalent height of fill, and then evaluated as an additional soil load. When concrete pipe has been installed underground, the soil-structure system will continually show an increase in load capacity. Data on concrete pipe, which have been removed from service and tested, indicate an increase in concrete strength and an increase in load carrying capacity of 10 to 40 percent. Settlement and consolidation will improve the soil structure surrounding the pipe, which also improves load carrying capacity.

### LIVE LOADS

The AASHTO design loads commonly used in the past were the HS 20 with a 32,000 pound axle load in the Normal Truck Configuration, and a 24,000 pound axle load in the Alternate Load Configuration (Figure 2). The average pressure intensity caused by a wheel load is calculated by Equation 3.

The AASHTO LRFD design loads are the HS 20 with a 32,000 pound axle load in the Normal Truck Configuration, and a 25,000 pound axle load in the Alternate Load Configuration (Figure 2).

## Earth Load Bedding Factor

**Table 12.10.4.3.2a-1 Bedding Factors for Circular Pipe.**

Pipe Diameter, in.	Standard Installations			
	Type 1	Type 2	Type 3	Type 4
12	4.4	3.2	2.5	1.7
24	4.2	3.0	2.4	1.7
36	4.0	2.9	2.3	1.7
72	3.8	2.8	2.2	1.7
144	3.6	2.8	2.2	1.7

# Extra Safety Factor for Type 1 Installations

## **C12.5.5**

The standard installations for direct design of concrete pipe were developed based on extensive parameter studies using the soil structure interaction program, SPIDA. Although past research validates that SPIDA soil structure models correlate well with field measurements, variability in culvert installation methods and materials suggests that the design for Type I installations be modified. This revision reduces soil structure interaction for Type I installations by ten percent until additional performance documentation on installation in the field is obtained.



# Pipe Indirect Design

## D-Load Equation

$$D = \left( \frac{12}{S_i} \right) \left( \frac{W_E + W_F}{B_{FE}} + \frac{W_L}{B_{FLL}} \right) \quad (12.10.4.3.1-1)$$

### Reinforced Pipe Classes for 0.01 inch Crack Per ASTM C 76 (lbs/ft/ft)

Class I	≤ 800
Class II	≤ 1000
Class III	≤ 1350
Class IV	≤ 2000
Class V	≤ 3000
Special Design	> 3000

# Class V Pipe (C76/M 170)

**TABLE 5 Design Requirements for Class V Reinforced Concrete Pipe<sup>A</sup>**

NOTE 1—See Section 5 for basis of acceptance specified by the owner.

The strength test requirements in pounds-force per linear foot of pipe under the three-edge-bearing method shall be either the D-load (test load expressed in pounds-force per linear foot per foot of diameter) to produce a 0.01-in. crack, or the D-loads to produce the 0.01-in. crack and the ultimate load as specified below, multiplied by the internal diameter of the pipe in feet.

Internal Designated Diameter, in.	D-load to produce a 0.01-in. crack		D-load to produce the ultimate load		Reinforcement, in. <sup>2</sup> /linear ft of pipe wall							
					3000		3750					
					Wall A		Wall B		Wall C			
	Concrete Strength, 6000 psi				Concrete Strength, 6000 psi				Concrete Strength, 6000 psi			
Wall Thickness, in.	Circular Reinforcement <sup>B</sup>		Elliptical Reinforcement <sup>C</sup>	Wall Thickness, in.	Circular Reinforcement <sup>B</sup>		Elliptical Reinforcement <sup>C</sup>	Wall Thickness, in.	Circular Reinforcement <sup>B</sup>		Elliptical Reinforcement <sup>C</sup>	
	Inner Cage	Outer Cage			Inner Cage	Outer Cage			Inner Cage	Outer Cage		
12	A	...	...	2	0.10	...	...	2¾	0.07 <sup>D</sup>	...	...	
15	A	...	...	2¼	0.14	...	...	3	0.07 <sup>D</sup>	...	...	
18	A	...	...	2½	0.19	...	0.16	3¼	0.10	...	...	
21	A	...	...	2¾	0.24	...	0.21	3½	0.10	...	...	
24	A	...	...	3	0.30	...	0.24	3¾	0.12	0.07	0.13	
27	A	...	...	3¼	0.38	0.23	0.42	4	0.14	0.08	0.16	
30	A	...	...	3½	0.41	0.25	0.46	4¼	0.18	0.11	0.20	
33	A	...	...	3¾	0.46	0.28	0.51	4½	0.23	0.14	0.25	
36	A	...	...	4	0.50	0.30	0.56	4¾	0.27	0.16	0.30	
42	A	...	...	4½	0.60	0.36	0.67	5¼	0.36	0.22	0.40	
48	A	...	...	5	0.73	0.44	0.81	5¾	0.47	0.28	0.52	
54	A	...	...	A	.....	...	...	6¼	0.58	0.35	0.64	
60	A	...	...	A	...	...	...	6¾	0.70	0.42	0.78	
66	A	...	...	A	...	...	...	7¼	0.84	0.50	0.93	
72	A	...	...	A	.....	...	...	7¾	0.99	0.59	1.10	
78	A	...	...	A	...	...	...	A	...	...	...	
84	A	...	...	A	...	...	...	A	...	...	...	
90	A	...	...	A	...	...	...	A	...	...	...	
96	A	...	...	A	...	...	...	A	...	...	...	

# Concrete Pipe

## Special Design/Direct Design –

### 12.10.4.2

- Flexure – 12.10.4.2.4.a & b
- Radial Tension – 12.10.4.2.4c
- Crack Control – 12.10.4.2.4d
- Shear – 12.10.4.2.5



FLEXURE



CRACK CONTROL



RADIAL TENSION



SHEAR

# The End

This presentation can be downloaded at: