

Design Data 40



Standard Installations and Bedding Factors for the Indirect Design Method

Foreword

The classic theory of earth loads on buried concrete pipe published in 1930 by A. Marston was developed for trench and embankment conditions (1).

In later work published in 1933, M. G. Spangler presented three bedding configurations and the concept of a bedding factor to relate the supporting strength of buried pipe to the strength obtained in a three-edge bearing test (2).

Spangler's theory proposed that the bedding factor for a particular pipeline and, consequently, the supporting strength of the buried pipe, is dependent on two installation characteristics:

- Width and quality of contact between the pipe and bedding.
- Magnitude of lateral pressure and the portion of the vertical height of the pipe over which it acts.

For the embankment condition, Spangler developed a general equation for the bedding factor, which partially included the effects of lateral pressure. For the trench condition, Spangler established conservative fixed bedding factors, which neglected the effects of lateral pressure, for each of the three beddings. This separate development of bedding factors for trench and embankment conditions resulted in the belief that lateral pressure becomes effective only at transition, or greater, trench widths. Such an assumption is not compatible with current engineering concepts and construction methods. It is reasonable to expect some lateral pressure to be effective at trench widths less than transition widths. Design Data No. 38 "Bedding Factors-Trench Installations", presents a conservative method for determining more appropriate trench bedding factors based on a linear variation of bedding factor values between that of a narrow trench and that at transition width (3).

Other limitations of Spangler's bedding factor research include:

- Loads considered acting only at the top of the pipe.
- Axial thrust not considered.
- Bedding width of test installations less than width designated in his bedding configurations.

- Standard beddings developed to fit assumed theories for soil support rather than ease of and methods of construction.
- Bedding materials and compaction levels not adequately defined.

C.P. Info No. 12 discusses these factors and their effect on buried pipe design in detail, and presents a method for determining bedding factors for the historical three beddings, B, C, and D, with lateral forces and modern installation methods being considered (4).

This publication, Design Data No. 40, allows the designer to take advantage of research results while using the indirect design method detailed in the American Concrete Pipe Association's (ACPA) Concrete Pipe Design Manual. The rather vague, historical B, C, and D beddings are replaced with four well defined Standard Installations. Application of the indirect design method presented in this Design Data requires use of various tables and graphs in the American Concrete Pipe Association's Concrete Pipe Design Manual. The necessary tables and graphs are listed in the following sections where appropriate.

Introduction

In 1970, ACPA began a long-range research program on the interaction of buried concrete pipe and soil. The research resulted in the comprehensive finite element computer program SPIDA, Soil-Pipe Interaction Design and Analysis, for the direct design of buried concrete pipe.

Since the early 1980's, SPIDA has been used for a variety of studies, including development of four new Standard Installations, and a simplified microcomputer design program, SIDD, Standard Installations Direct Design.

This Design Data No. 40 replaces the historical B, C, and D beddings used in the indirect design method with the four new Standard Installations, and presents a state-of-the-art method for determination of bedding factors for the Standard Installations. Pipe and installation terminology as used in the Installations, SIDD, and this Design Data are defined in Figure 1.

Figure 1 Pipe/Installation Terminology

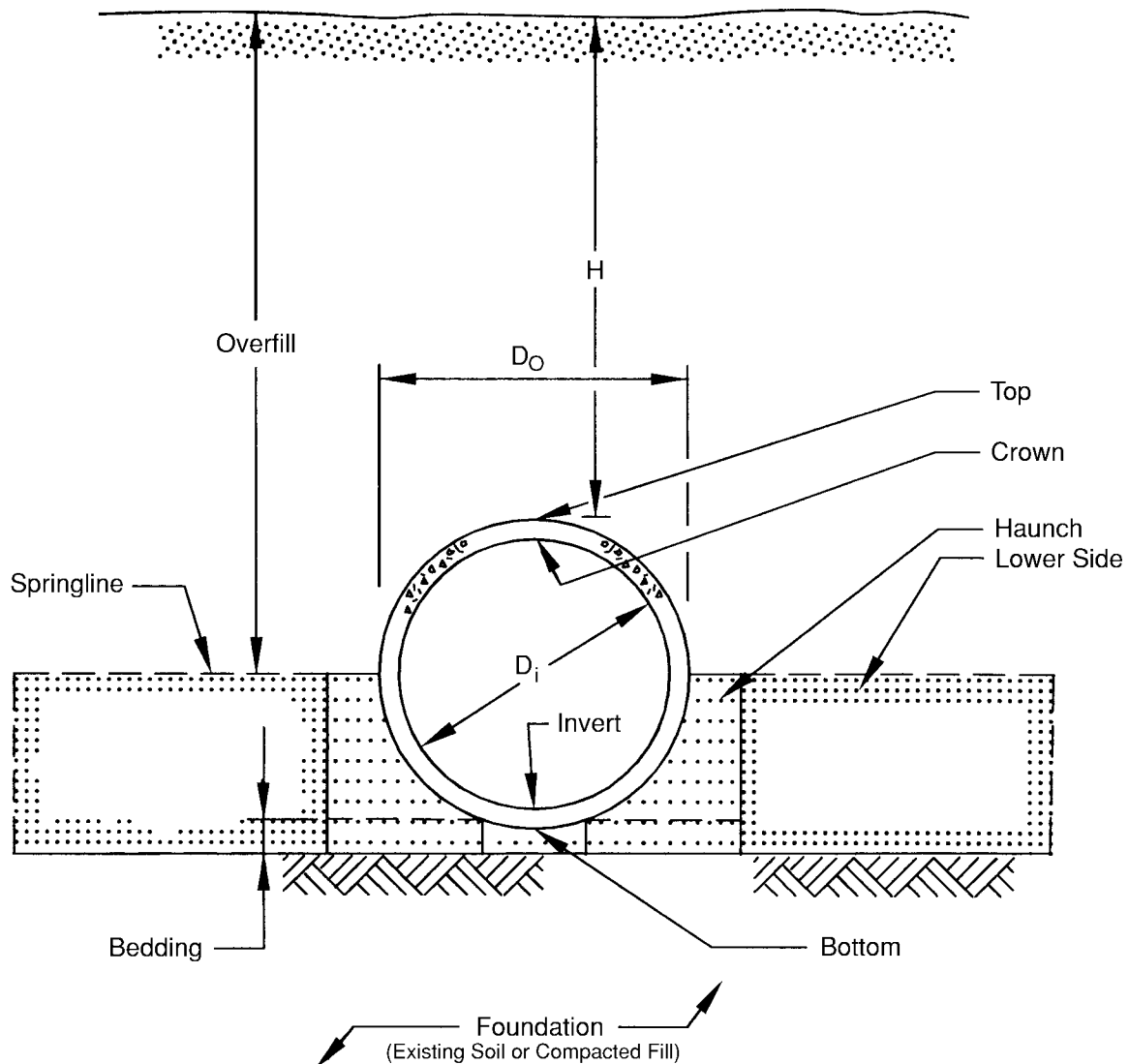

Standard Installations

Through consultations with engineers and contractors, and with the results of numerous SPIDA parameter studies, four new Standard Installations were developed and are presented in Figures 2 and 3. The SPIDA studies were conducted for positive projection embankment conditions, which are the worst-case vertical load conditions for pipe, and which provide conservative results for other embankment and trench conditions.

The parameter studies confirmed ideas postulated from past experience and proved the following concepts:

- Loosely placed, uncompacted bedding directly under the invert of the pipe significantly reduces stresses in the pipe.
- Soil in those portions of the bedding and haunch

areas directly under the pipe is difficult to compact.

- The soil in the haunch area from the foundation to the pipe springline provides significant support to the pipe and reduces pipe stresses.
- Compaction level of the soil directly above the haunch, from the pipe springline to the top of the pipe grade level, has negligible effect on pipe stresses. Compaction of the soil in this area is not necessary unless required for pavement structures.
- Installation materials and compaction levels below the springline have a significant effect on pipe structural requirements.

Table 1 Equivalent USCS and AASHTO Soil Classifications for SIDD Soil Designations

SIDD Soil	Representative Soil Types		Percent Compaction	
	USCS,	AASHTO	Standard Proctor	Standard Proctor
Gravelly Sand (Category 1)	SW, SP, GW, GP	A1,A3	100	95
			95	90
			90	85
			85	80
			80	75
			61	59
Sandy Silt (Category II)	GM, SM, ML, Also GC, SC with less than 20% passing #200 sieve	A2, A4	100	95
			95	90
			90	85
			85	80
			80	75
			49	46
Silty Clay (Category III)	CL, MH, GC, SC	A5, A6	100	90
			95	85
			90	80
			85	75
			80	70
			45	40
	CH		100	90
			95	85
			90	80
			90	80
			90	80
			45	40

The four Standard Installations provide an optimum range of soil-pipe interaction characteristics. For the relatively high quality materials and high compaction effort of a Type 1 Installation, a lower strength pipe is required. Conversely, a Type 4 Installation requires a higher strength pipe, because it was developed for conditions of little or no control over materials or compaction.

Generic soil types are designated in Figure 2 and Figure 3. The Unified Soil Classification System (USCS) and American Association of State Highway and Transportation Officials (AASHTO) soil classifications equivalent to the generic soil types in the Standard Installations are presented in Table 1.

Load Pressures

SPIDA was programmed with the Standard Installations and many design runs were made. An evaluation of the output of the designs by Dr. Frank J. Heger produced a load pressure diagram significantly different than proposed by previous theories. See Figure 4. This difference is particularly significant under the pipe in the lower haunch area and is due in part to the assumption of the existence of partial voids adjacent to

the pipe wall in this area. SIDD uses this pressure data to determine moments, thrusts, and shears in the pipe wall, and then uses the ACPA limit states design method to determine the required reinforcement areas to handle the pipe wall stresses (5). Using this method, each criteria that may limit or govern the design is considered separately in the evaluation of overall design requirements. SIDD, which is based on the four Standard Installations, is a stand-alone program developed by the American Concrete Pipe Association.

The Federal Highway Administration, FHWA, developed a microcomputer program, PIPECAR, for the direct design of concrete pipe prior to the development of SIDD. PIPECAR determines moment, thrust, and shear coefficients from either of two systems, a radial pressure system developed by Olander in 1950 and a uniform pressure system developed by Paris in the 1920's, and then also uses the ACPA limit states design method to determine the required reinforcement areas to handle the pipe wall stresses. The SIDD system has been incorporated into PIPECAR as a state-of-the-art enhancement.

Figure 2 Standard Embankment Installations

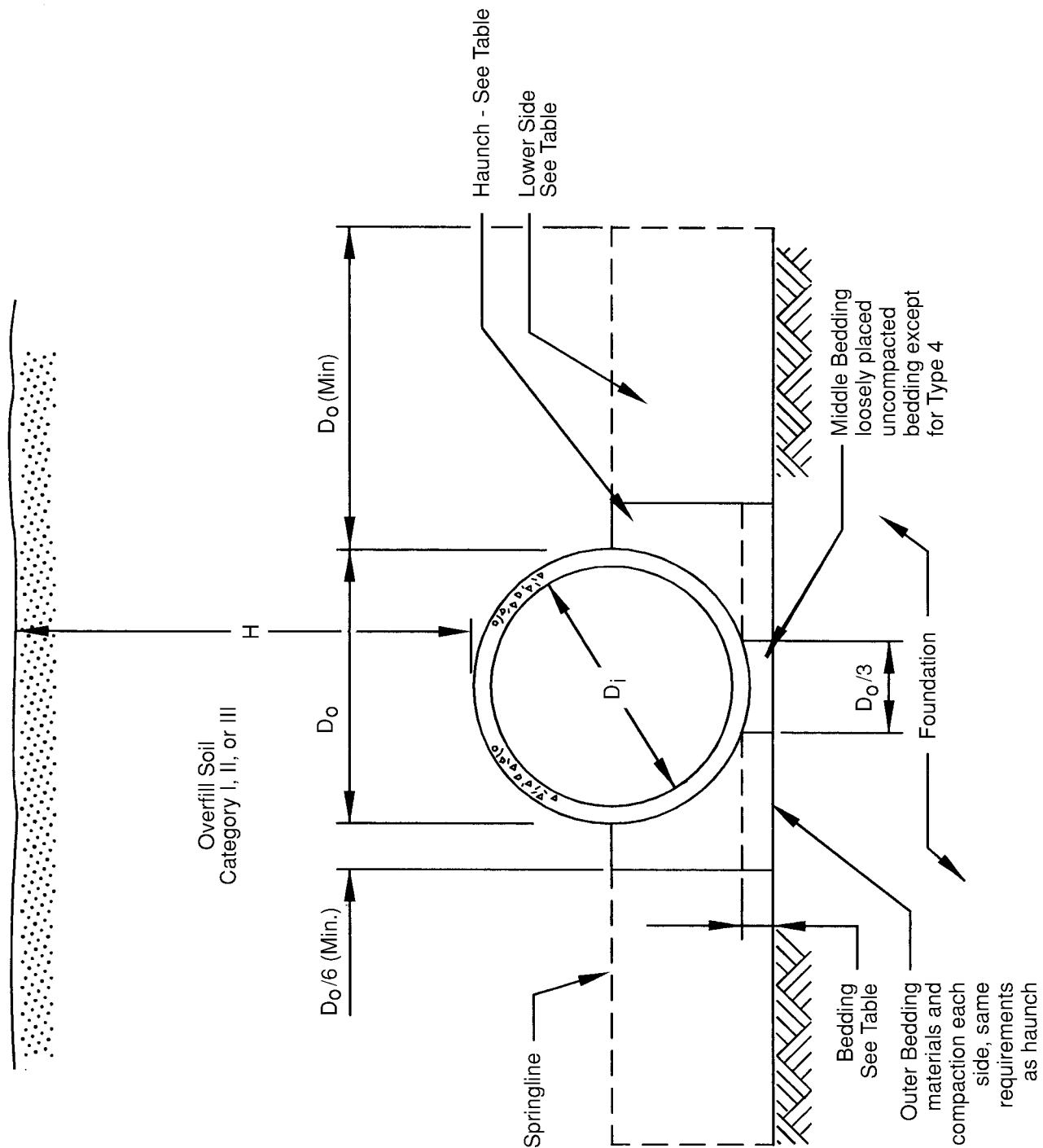

Table 2 Standard Embankment Installations Soils and Minimum Compaction Requirements

Installation Type	Bedding Thickness	Haunch and Outer Bedding	Lower Side
Type 1	D _o /24 minimum, not less than 75 mm (3"). If rock foundation, use D _o /12 minimum, not less than 150 mm (6").	95% Category I	90% Category I, 95% Category II, or 100% Category III
Type 2	D _o /24 minimum, not less than 75 mm (3"). If rock foundation, use D _o /12 minimum, not less than 150 mm (6").	90% Category I or 95% Category II	85% Category I, 90% Category II, or 95% Category III
Type 3	D _o /24 minimum, not less than 75 mm (3"). If rock foundation, use D _o /12 minimum, not less than 150 mm (6").	85% Category I, 90% Category II, or 95% Category III	85% Category I, 90% Category II, or 95% Category III
Type 4	D _o /24 minimum, not less than 75 mm (3"). If rock foundation, use D _o /12 minimum, not less than 150 mm (6").	No compaction required, except if Category III, use 85% Category III	No compaction required, except if Category III, use 85% Category III

Notes:

1. Compaction and soil symbols - i.e. "95% Category I" refers to Category 1 soil material with a minimum standard Proctor compaction of 95%. See Table 1 for equivalent modified Proctor values.
2. Soil in the outer bedding, haunch, and lower side zones, except within D_o/3 from the pipe springline, shall be compacted to at least the same compaction as the majority of soil in the overfill zone.
3. **Subtrenches**
 - 3.1 A subtrench is defined as a trench with its top below finished grade by more than 0.1 H or, for roadways, its top is at an elevation lower than 0.3 m (1') below the bottom of the pavement base material.
 - 3.2 The minimum width of a subtrench shall be 1.33 D_o or wider if required for adequate space to attain the specified compaction in the haunch and bedding zones.
 - 3.3 For subtrenches with walls of natural soil, any portion of the lower side zone in the subtrench wall shall be at least as firm as an equivalent soil placed to the compaction requirements specified for the lower side zone and as firm as the majority of soil in the overfill zone, or shall be removed and replaced with soil compacted to the specified level.

Figure 3 Standard Trench Installations

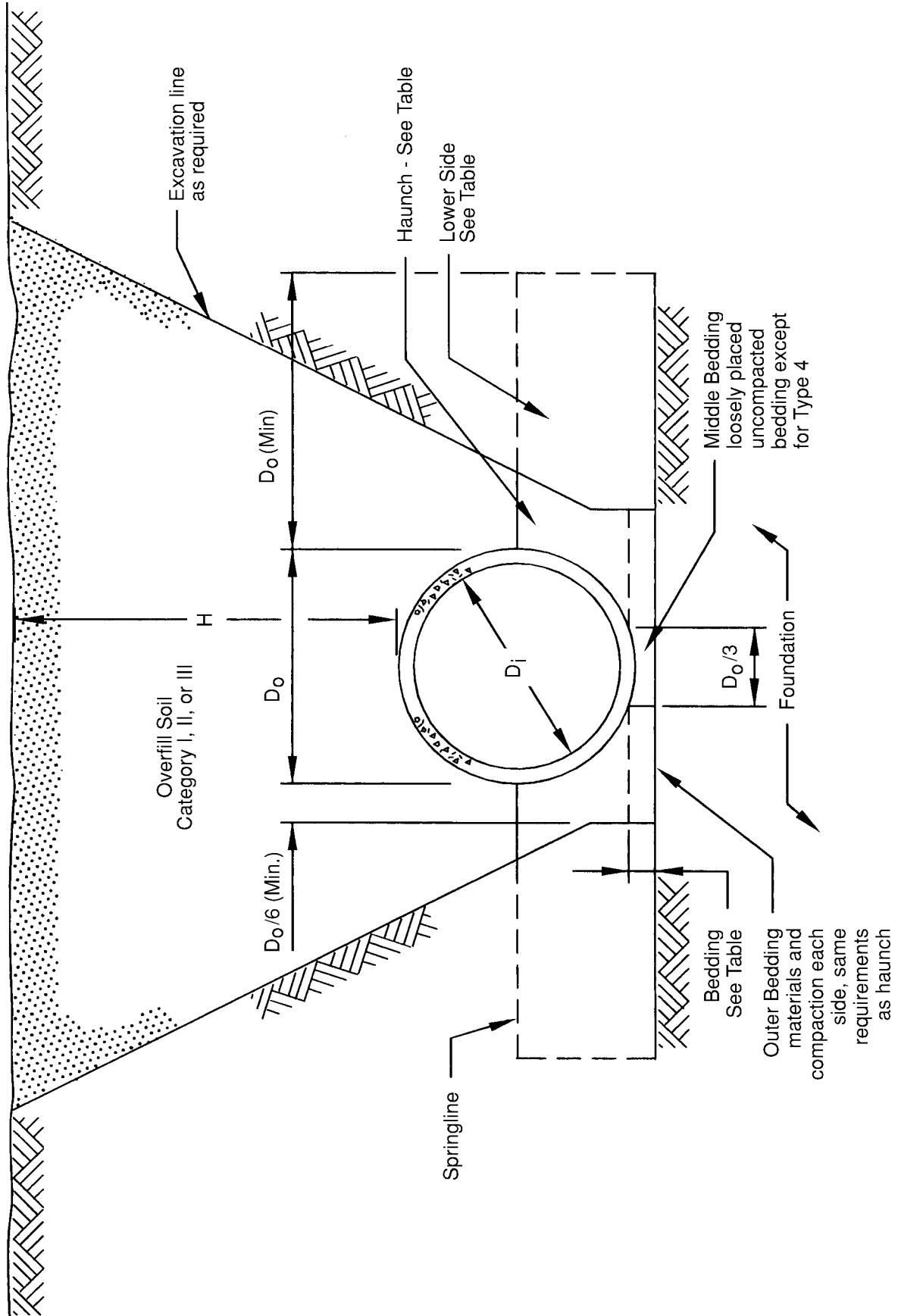

Table 3 Standard Trench Installations Soils and Minimum Compaction Requirements

Installation Type	Bedding Thickness	Haunch and Outer Bedding	Lower Side
Type 1	D _o /24 minimum, not less than 75 mm (3"). If rock foundation, use D _o /12 minimum, not less than 150 mm (6").	95% Category I	90% Category I, 95% Category II, or 100% Category III
Type 2	D _o /24 minimum, not less than 75 mm (3"). If rock foundation, use D _o /12 minimum, not less than 150 mm (6").	90% Category I or 95% Category II	85% Category I, 90% Category II, or 95% Category III
Type 3	D _o /24 minimum, not less than 75 mm (3"). If rock foundation, use D _o /12 minimum, not less than 150 mm (6") .	85% Category I, 90% Category II, or 95% Category III	85% Category I, 90% Category II, or 95% Category III
Type 4	D _o /24 minimum, not less than 75 mm (3"). If rock foundation, use D _o /12 minimum, not less than 150 mm (6").	No compaction required, except if Category III, use 85% Category III	No compaction required, except if Category III, use 85% Category III

Notes:

1. Compaction and soil symbols - i.e. "95% Category I"- refers to Category I soil material with minimum standard Proctor compaction of 95%. See Table 1 for equivalent modified Proctor values.
2. The trench top elevation shall be no lower than 0.1 H below finished grade or, for roadways, its top shall be no lower than an elevation of 0.3 m (1') below the bottom of the pavement base material.
3. Soil in bedding and haunch zones shall be compacted to at least the same compaction as specified for the majority of soil in the backfill zone.
4. The trench width shall be wider than shown if required for adequate space to attain the specified compaction in the haunch and bedding zones.
5. For trench walls that are within 10 degrees of vertical, the compaction or firmness of the soil in the trench walls and lower side zone need not be considered.
6. For trench walls with greater than 10 degree slopes that consist of embankment, the lower side shall be compacted to at least the same compaction as specified for the soil in the backfill zone.

Figure 4 Arching Coefficients and Heger Earth Pressure Distributions

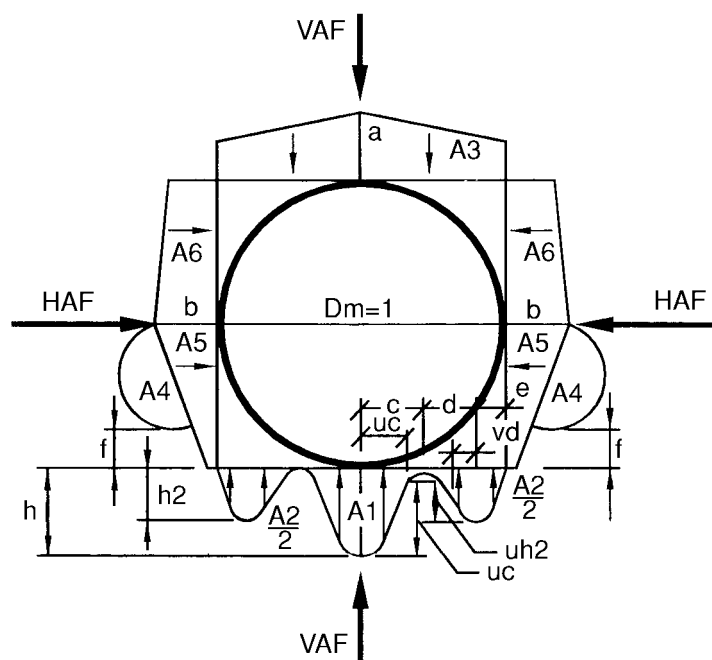

Installation Type	VAF	HAF	A1	A2	A3	A4	A5	A6	a	b	c	e	f	u	v
1	135	0.45	0.62	0.73	1.35	0.19	0.08	0.18	1.40	0.40	0.18	0.08	0.05	0.80	0.80
2	1.40	0.40	0.85	0.55	1.40	0.15	0.08	0.17	1.45	0.40	0.19	0.10	0.05	0.82	0.70
3	1.40	0.37	1.05	0.35	1.40	0.10	0.10	0.17	1.45	0.36	0.20	0.12	0.05	0.85	0.60
4	1.45	0.30	1.45	0.00	1.45	0.00	0.11	0.19	1.45	0.30	0.25	0.00	-	0.90	-

Notes:

- VAF and HAF are vertical and horizontal arching factors. These coefficients represent non-dimensional total vertical and horizontal loads on the pipe, respectively. The actual total vertical and horizontal loads are (VAF) X (PL) and (HAF) X (PL), respectively, where PL is the prism load.
- PL, the prism load, is the weight of the column of earth cover over the pipe outside diameter and is calculated as:

$$PL = w \left[\left(H + \frac{D_0 (4 - \pi)}{96} \right) \right] \frac{D_0}{12}$$

- Coefficients A1 through A6 represent the integration of non-dimensional vertical and horizontal components of soil pressure under the indicated portions of the component pressure diagrams (i.e. the area under the component pressure diagrams). The pressures are assumed to vary either parabolically or linearly, as shown, with the non-dimensional magnitudes at governing points represented by h_1 , h_2 , uh_1 , vh_2 , a and b . Non-dimensional horizontal and vertical dimensions of component pressure regions are defined by c , d , e , vc , vd , and f coefficients.
- d is calculated as $(0.5-c-e)$.
 h_1 is calculated as $(1.5A1) / (c) (1+u)$.
 h_2 is calculated as $(1.5A2) / [(d) (1+v) + (2e)]$

The SPIDA design runs with the Standard Installations were made with medium compaction of the bedding under the middle-third of the pipe, and with some compaction of the overfill above the springline of the pipe. This middle-third area under the pipe in the Standard Installations has been designated as loosely placed, uncompacted material. The intent is to maintain a slightly yielding bedding under the middle-third of the pipe so that the pipe may settle slightly into the bedding and achieve improved load distribution. Compactive efforts in the middle-third of the bedding with mechanical compactors is undesirable, and could produce a hard flat surface, which would result in highly concentrated stresses in the pipe invert similar to those experienced in the three-edge bearing test. The most desirable construction sequence is to place the bedding to grade; install the pipe to grade; compact the bedding outside of the middle-third of the pipe; and then place and compact the haunch area up to the springline of the pipe. The bedding outside the middle-third of the pipe may be compacted prior to placing the pipe.

As indicated in Figures 2 and 3, when the design includes surface loads, the overfill and lower side areas should be compacted as required to support the surface load. With no surface loads or surface structure requirements, these areas need not be compacted.

Bedding Factors

Although developed for the direct design method, the Standard Installations are readily applicable to and simplify the indirect design method, which is presented in detail in the Concrete Pipe Handbook (6). The Standard Installations are easier to construct and provide more realistic designs than the historical B, C, and D beddings. Development of bedding factors for the Standard Installations, as presented in the following paragraphs, follows the concepts of reinforced concrete design theories. The basic definition of bedding factor is that it is the ratio of maximum moment in the three-edge bearing test to the maximum moment in the buried condition, when the vertical loads under each condition are equal:

$$Bf = \frac{M_{TEST}}{M_{FIELD}} \quad [1]$$

where:

- Bf = bedding factor
 M_{TEST} = maximum moment in pipe wall under three-edge bearing test load, inch-pounds
 M_{FIELD} = maximum moment in pipe wall under field loads, inch-pounds

Consequently, to evaluate the proper bedding factor relationship, the vertical load on the pipe for each

condition must be equal, which occurs when the springline axial thrusts for both conditions are equal. In accordance with the laws of statics and equilibrium, M_{TEST} and M_{FIELD} are:

$$M_{TEST} = [0.318N_{FS}] X [D + t] \quad [2]$$

$$M_{FIELD} = [M_{FI}] - [0.38tN_{FI}] - [0.125N_{FI} X c] \quad [3]$$

where:

- N_{FS} = axial thrust at the springline under a three-edge bearing test load, Newtons per meter (pounds per foot)
D = internal pipe diameter, mm (inches)
t = pipe wall thickness, mm (inches)
 M_{FI} = moment at the invert under field loading, (Newton-mm)/m ((inch-pounds)/ft)
 N_{FI} = axial thrust at the invert under field loads, Newtons per meter (pounds per foot)
c = thickness of concrete cover over the inner reinforcement, mm (inches)

Substituting equations 2 and 3 into equation 1:

$$Bf = \frac{[0.318N_{FS}] X [D+t]}{[M_{FI}] - [0.38tN_{FI}] - [0.125N_{FI} X c]} \quad [4]$$

Using SIDD, bedding factors were determined for a range of pipe diameters and depths of burial. These calculations were based on one inch cover over the reinforcement, a moment arm of 0.875d between the resultant tensile and compressive forces, and a reinforcement diameter of 0.075t. Evaluations indicated that for A, B, and C pipe wall thicknesses, there was negligible variation in the bedding factor due to pipe wall thickness or the concrete cover, c, over the reinforcement. The resulting bedding factors are presented in Table 4.

Design Procedure

The six-step indirect design procedure presented in the Concrete Pipe Design Manual for the selection of pipe strength is still appropriate (7).

1. Determination of Earth Load
2. Determination of Live Load
3. Selection of Standard Installation
4. Determination of Bedding Factor
5. Application of Factor of Safety
6. Selection of Pipe Strength

Table 4 Bedding Factors, Embankment Conditions, B_{fe}

Pipe Diameter	Standard Installation			
	Type 1	Type 2	Type 3	Type 4
300 mm (12 in.)	4.4	3.2	2.5	1.7
600 mm (24 in.)	4.2	3.0	2.4	1.7
900 mm (36 in.)	4.0	2.9	2.3	1.7
1800 mm (72 in.)	3.8	2.8	2.2	1.7
3600 mm (144 in.)	3.6	2.8	2.2	1.7

Notes:

1. For pipe diameters other than listed in Table 4, embankment condition factors, B_{fe} can be obtained by interpolation.
2. Bedding factors are based on the soils being placed with the minimum compaction specified in Tables 2 and 3 for each standard installation.

The use of the Standard Installations and bedding factors presented in this Design Data simplifies the indirect design procedure. Changes to and use of each step of the design procedure are described in the following paragraphs.

Determination of Earth Load

The Design Manual tables and graphs can be used to determine the earth loads on a buried pipe. These tables and graphs refer to soils by common names, while SIDD soils are referred to by generic soil types. Table 5 presents the relationship between these two different methods of soil designations.

One of the informative calculations output by SPIDA is the arching factor, which is defined as the ratio of the calculated vertical load on the pipe to the weight of the prism of earth directly above the outside diameter of the pipe. Evaluation of the arching factor from the SPIDA studies shows that the factor approaches a value of 1.45 as an upper limit for any of the four Standard Installations.

For positive projection embankment installations, since the arching factor will not exceed 1.45, the appropriate earth load can be obtained from Design

Manual graphs (Figures 163, 164, 165 and 166) for embankment earth load for the range of $r_{sd}p$ values from zero to 0.5. When the product of r_{sd} , settlement ratio, and p , projection ratio, is zero, the earth load on the pipe is equal to the weight of the prism of soil above the pipe. For positive values of $r_{sd}p$, the load on the pipe will be greater than the weight of the prism of soil above the pipe, and for negative values of $r_{sd}p$, the load on the pipe will be less than the weight of the prism of soil above the pipe.

For trench installations, Design Manual tables (Tables 13 through 42) and graphs (Figures 147, 148, 149, and 150) for earth load can be used as is to determine the load on the pipe. These tables and graphs take into account the beneficial effects of upward frictional forces on the trench wall in reducing the load on the pipe to less than the prism load.

Determination of Live Load

Design Manual Table 45 can be used as is to determine the live load for both the trench and embankment conditions.

Table 5 Relationship of ACPA Design Manual Soil Designations to SIDD Soil Designations

ACPA Design Manual Soils	SIDD Soils
Sand and Gravel	CATEGORY I
Saturated Top Soil	CATEGORY II
Ordinary Clay and Saturated Clay	CATEGORY III

Note:

1. The USCS and AASHTO soil classifications equivalent to the generic soil types designated in the Standard Installations are presented in Table 1.

Selection of Standard Installation

The selection of a Standard Installation for a project should be based on an evaluation of the quality of construction and inspection anticipated. A Type 1 Standard Installation requires the highest construction quality and degree of inspection. Required construction quality is reduced for a Type 2 Standard Installation, and reduced further for a Type 3 Standard Installation. A Type 4 Standard Installation requires virtually no construction or quality inspection. Consequently, a Type 4 Standard Installation will require a higher strength pipe, and a Type I Standard Installation will require a lower strength pipe for the same depth of installation.

Determination of Bedding Factor

Table 4 presents embankment bedding factors, B_{fe} , for each of the Standard Installations.

For trench installations as discussed in C.P. Info No. 12 and in the Design Manual, experience indicates that active lateral pressure increases as trench width increases to the transition width, provided the sidefill is compacted. A SIDD parameter study of the Standard Installations indicates the bedding factors are constant for all pipe diameters under conditions of zero lateral pressure on the pipe. These bedding factors exist at the interface of the pipewall and the soil and are called minimum bedding factors, B_{fo} , to differentiate them from the fixed bedding factors developed by Spangler. Table 6 presents the minimum bedding factors.

A conservative linear variation is assumed between the minimum bedding factor and the bedding factor for the embankment condition, which begins at transition width.

The equation for the variable trench bedding factor, modified for use with the Standard Installations, is:

$$B_{fv} = \frac{[B_{fe} - B_{fo}][B_d - B_c]}{[B_{dt} - B_c]} + B_{fo} \quad [5]$$

where:

- B_c = outside horizontal span of pipe, mm (feet)
- B_d = trench width at top of pipe, mm (feet)
- B_{dt} = transition width at top of pipe, mm (feet)
- B_{fe} = bedding factor, embankment
- B_{fo} = minimum bedding factor, trench
- B_{fv} = variable bedding factor, trench

The Design Manual tables (Tables 13 through 42) for trench earth loads present transition width values which are sufficiently accurate for use as values for B_{dt} in the preceding equation.

For pipe installed with 1.95 m (6.5 ft) or less of overfill and subjected to truck loads, the controlling maximum moment may be at the crown rather than the invert. Consequently, the use of an earth load bedding factor may produce unconservative designs. Crown and invert moments of pipe for a range of diameters and burial depths subjected to HS20 truck live loadings were evaluated. Also evaluated, was the effect of bedding angle and live load angle (width of loading on the pipe). When HS20 live loadings are encountered to a significant value, the live load bedding factors, B_{fL} , presented in Table 7A or B are satisfactory for a Type 4 Standard Installation and become increasingly conservative for Types 3, 2, and 1. Limitations on B_{fL} are discussed in the section on Selection of Pipe Strength.

Application of Factor of Safety

The indirect design method for concrete pipe is similar to the common working stress method of steel design, which employs a factor of safety between yield stress and the desired working stress. In the indirect

Table 6 Trench Minimum Bedding Factors, B_{fo}

Standard Installation	Minimum Bedding Factor, B_{fo}
Type 1	2.3
Type 2	1.9
Type 3	1.7
Type 4	1.5

Note:

1. Bedding factors are based on the soils being placed with the minimum compaction specified in Figures 2 and 3 for each Standard Installation.
2. For pipe installed in trenches dug in previously constructed embankment, the load and the bedding factor should be determined as an embankment condition unless the backfill placed over the pipe is of lesser compaction than the embankment.

method, the factor of safety is defined as the relationship between the ultimate strength D-load and the 0.3 mm (0.01-inch) crack D-load. This relationship is specified in the ASTM Standards C 76 and C 655 on concrete pipe. The relationship between ultimate D-load and 0.3 mm (0.01-inch) crack D-load is 1.5 for 0.3 mm (0.01 inch) crack D-loads of 2,000 or less; 1.25 for 0.3 mm (0.01 inch) crack D-loads of 3,000 or more; and a linear reduction from 1.5 to 1.25 for 0.3 mm (0.01-inch) crack D-loads between more than 2,000 and less than 3,000. Therefore, a factor of safety of 1.0 should be applied if the 0.3 mm (0.01 inch) crack strength is used as the design criterion rather than the ultimate strength. The 0.3 mm (0.01-inch) crack width is an arbitrarily chosen test criterion and not a criteria for field performance or service limit.

Section of Pipe Strength

The required three-edge bearing strength of circular reinforced concrete pipe expressed as D-load:

$$D\text{-load} = \left[\frac{W_E}{B_{fe}} + \frac{W_L}{B_{fLL}} \right] \left[\frac{F.S.}{D} \right] \quad [6]$$

where:

- W_E = earth load on pipe, kg/m (pounds per linear foot)
- W_L = live load on pipe, kg/m (pounds per linear foot)
- B_{fe} = earth load bedding factor
- B_{fLL} = live load bedding factor
- F.S. = factor of safety
- D = pipe diameter, mm (feet)

When an HS20 truck live loading is applied to the pipe, use the live load bedding factor, B_{fLL} as indicated in Equation 6, unless the earth load bedding factor, B_{fe} , is of lesser value, in which case, use the lower B_{fe} value in place of B_{fLL} . For example, with Type 4 Standard Installation of a 1200 mm (48inch) diameter pipe under 0.3 m (1.0 feet) of fill, the factors used would be $B_{fe} = 1.7$ and $B_{fLL} = 1.5$; but under 0.75 m (2.5 feet) or greater fill, the factors used would be $B_{fe} = 1.7$ and $B_{fLL} = 1.7$ rather than 2.2. For trench installations with trench widths less than transition width, B_{fLL} would be compared to the variable trench bedding factor, B_{fv} .

The use of the six-step indirect design method is illustrated by examples on the following pages.

Table 7A Bedding Factors, B_{fLL} , for HS20 Live Loadings

Fill Height, Ft.	Pipe Diameter, Inches										
	12	24	36	48	60	72	84	96	108	120	144
0.5	2.2	1.7	1.4	1.3	1.3	1.1	1.1	1.1	1.1	1.1	1.1
1.0	2.2	2.2	1.7	1.5	1.4	1.3	1.3	1.3	1.1	1.1	1.1
1.5	2.2	2.2	2.1	1.8	1.5	1.4	1.4	1.3	1.3	1.3	1.1
2.0	2.2	2.2	2.2	2.0	1.8	1.5	1.5	1.4	1.4	1.3	1.3
2.5	2.2	2.2	2.2	2.2	2.0	1.8	1.7	1.5	1.4	1.4	1.3
3.0	2.2	2.2	2.2	2.2	2.2	2.2	1.8	1.7	1.5	1.5	1.4
3.5	2.2	2.2	2.2	2.2	2.2	2.2	1.9	1.8	1.7	1.5	1.4
4.0	2.2	2.2	2.2	2.2	2.2	2.2	2.1	1.9	1.8	1.7	1.5
4.5	2.2	2.2	2.2	2.2	2.2	2.2	2.2	2.0	1.9	1.8	1.7
5.0	2.2	2.2	2.2	2.2	2.2	2.2	2.2	2.2	2.0	1.9	1.8
5.5	2.2	2.2	2.2	2.2	2.2	2.2	2.2	2.2	2.2	2.0	1.9
6.0	2.2	2.2	2.2	2.2	2.2	2.2	2.2	2.2	2.2	2.1	2.0
6.5	2.2	2.2	2.2	2.2	2.2	2.2	2.2	2.2	2.2	2.2	2.2

Note:

- For pipe diameters other than listed in Table 7A, B_{fLL} values can be obtained by interpolation.

Example 1:

Given: A 600 mm (24-inch) diameter circular concrete pipe is to be installed in a positive projecting embankment condition with 10.6 m (35 feet) of 1,922 kg/m³ (120 pounds per cubic foot) soil overfill.

Find: The required pipe strength in terms of the 0.3 mm (0.01-inch) crack D-load for each of the Standard Installation Types for r_{sd}p's of 0.0 and 0.5.

Solution:

1. Determination of Earth Load (WE)

Calculations are shown for the Type 4 Standard Installation, but results for all types are tabulated in the Answer section of this example.

From Design Manual Figure 163 (r_{sd}p=0), the earth load based on 1,600 kg/m³ (100 pounds per cubic foot) overfill is 13,422 kg per linear meter (9,000 pounds per linear foot). Increase the earth load 20 percent for the given 1,922 kg/m³ (120 pounds per cubic foot) soil overfill:

$$WE = 1.2 \times 13,422 = 16,106 \text{ kg/m}$$

or

$$WE = 1.2 \times 9,000 = 10,800 \text{ pounds per linear foot}$$

2. Determination of Live Load (WL)

From the Design Manual Table 45, live load is negligible at a depth of 10.6 m (35 feet).

3. Selection of Standard Installation

Calculations for a Type 4 Standard Installation will be shown, but results for all the Standard Installations will be tabulated.

4. Determination of Bedding Factor

From Table 4, a bedding factor for the embankment condition, B_{fe}, of 1.7 is obtained for a Type 4 Standard Installation. Since live load is considered negligible under 10.6 m (35 feet) of overfill, a live load bedding factor is not required.

5. Application of Factor of Safety (F.S.)

A factor of safety of 1.0 will be used since the D-load for 0.3 mm (0.01-inch) crack strength is desired.

6. Selection of Pipe Strength

Equation 6 is used to determine the required D-load strength:

Table 7B Bedding Factors, B_{fLL}, for HS20 Live Loadings (Metric)

Fill Height, Meters	Pipe Diameter, Millimeters										
	300	600	900	1200	1500	1800	2100	2400	2700	3000	3600
0.15	2.2	1.7	1.4	1.3	1.3	1.1	1.1	1.1	1.1	1.1	1.1
0.30	2.2	2.2	1.7	1.5	1.4	1.3	1.3	1.3	1.1	1.1	1.1
0.45	2.2	2.2	2.1	1.8	1.5	1.4	1.4	1.3	1.3	1.3	1.1
0.60	2.2	2.2	2.2	2.0	1.8	1.5	1.5	1.4	1.4	1.3	1.3
0.75	2.2	2.2	2.2	2.2	2.0	1.8	1.7	1.5	1.4	1.4	1.3
0.90	2.2	2.2	2.2	2.2	2.2	2.2	1.8	1.7	1.5	1.5	1.4
1.05	2.2	2.2	2.2	2.2	2.2	2.2	1.9	1.8	1.7	1.5	1.4
1.20	2.2	2.2	2.2	2.2	2.2	2.2	2.1	1.9	1.8	1.7	1.5
1.35	2.2	2.2	2.2	2.2	2.2	2.2	2.2	2.0	1.9	1.8	1.7
1.50	2.2	2.2	2.2	2.2	2.2	2.2	2.2	2.2	2.0	1.9	1.8
1.65	2.2	2.2	2.2	2.2	2.2	2.2	2.2	2.2	2.2	2.0	1.9
1.80	2.2	2.2	2.2	2.2	2.2	2.2	2.2	2.2	2.2	2.1	2.0
1.95	2.2	2.2	2.2	2.2	2.2	2.2	2.2	2.2	2.2	2.2	2.2

Note:

- For pipe diameters other than listed in Table 7B, B_{fLL} values can be obtained by interpolation.

$$D_{0.3\text{mm}} = \left[\frac{W_E}{B_{fe}} + \frac{W_L}{B_{fLL}} \right] \times \left[\frac{F.S.}{D} \right] \times (9.81)$$

$$D_{0.3\text{mm}} = \left[\frac{16,106}{1.7} + 0 \right] \times \left[\frac{1.0}{600} \right] \times (9.81)$$

$$D_{0.3\text{mm}} = 155 \text{ N/m/mm}$$

Note: The factor of 9.81 in the above equation is required to convert kg mass to N force.

or

$$D_{0.01} = \left[\frac{W_E}{B_{fe}} + \frac{W_L}{B_{fLL}} \right] \times \left[\frac{F.S.}{D} \right]$$

$$D_{0.01} = \left[\frac{10,800}{1.7} + 0 \right] \times \left[\frac{1.0}{2} \right]$$

$$D_{0.01} = 3,180$$

Example 2:

Given: A 900 mm (36-inch) diameter, wall B, concrete pipe is to be installed in a 1.5 m (5 foot) wide, B_{dt} , trench with 1.5 m (5 feet) of 1,922 kg/m³ (120 pounds per cubic foot) of sand and gravel overfill.

Find: The required pipe strength in terms of 0.3 mm (0.01-inch) crack D-load for each of the Standard Installation Types.

Solution:

1. Determination of Earth Load (WE)

Calculations are shown for the Type I Standard

Installation, and results for all Types of Standard Installations are tabulated in the Answers section of this example. From Design Manual Table 24A, the earth load based on 1,600 kg (100 pounds per cubic foot) overfill of sand and gravel material is 3,175 kg/m (2,129 pounds per linear foot). Increase the earth load by 20 percent for the required 1,922 kg/m³ (120 pounds per cubic foot) overfill.

$$W_E = 1.20 \times 3,175 = 3,810 \text{ kg/m}$$

or

$$W_E = 1.20 \times 2,129 = 2,560 \text{ pounds per linear foot}$$

2. Determination of Live Load (WL)

From Design Manual Table 45, the live load is 1,000 kg/m (670 pounds per linear foot) at a depth of 1.5 m (5 feet).

3. Selection of Standard Installation

All of the Standard Installations are evaluated and tabulated for this example to illustrate the effects of each.

4. Determination of Bedding Factor

From Table 4, an embankment condition bedding factor, B_{fe} , of 4.0 is obtained for a Standard Installation Type 1. From Design Manual Table 24A, a transition width, B_{dt} , is 1.7 m (5.6 feet). For a 900 mm (36 inch) diameter, wall B concrete pipe, the outside diameter, B_c , is 1.1 m (44 inches). From Table 6, a trench minimum bedding factor, B_{fo} , of 2.3 is obtained. Equation 5 is used to determine the trench variable bedding factor, B_{fv} .

Answers – Example 1

Installation Type	$r_{sd}p = 0$, Figure 163			$r_{sd}p = 0.5$, Figure 166		
	W_E	B_{fe}	$D_{0.01}$	W_E	B_{fe}	$D_{0.01}$
Type 1	10,800	4.2	1,290	16,200	4.2	1,930
Type 2	10,800	3.0	1,800	16,200	3.0	2,700
Type 3	10,800	2.4	2,250	16,200	2.4	3,380
Type 4	10,800	1.7	3,180	16,200	1.7	4,770
Type 1 (S.I. units)	16,106	4.2	62.7	24,160	4.2	94
Type 2 (S.I. units)	16,106	3.0	87.8	24,160	3.0	132
Type 3 (S.I. units)	16,106	2.4	110	24,160	2.4	165
Type 4 (S.I. units)	16,106	1.7	155	24,160	1.7	232

$$B_{fv} = \frac{[B_{fe} - B_{fo}] \times [B_d - B_c]}{[B_{dt} - B_c]} + B_{fo}$$

$$B_{fv} = \frac{[4.0 - 2.3] \times [1.5 - 1.1]}{[1.7 - 1.1]} + 2.3$$

$$B_{fv} = 3.4$$

From Table 7, a live load bedding factor, B_{fLL} , of 2.2 is obtained. Since 2.2 is less than B_{fv} , a B_{fLL} of 2.2 will be used.

- Application of Factor of Safety (F.S.)
A factor of safety of 1.0 will be used since the D-load for 0.3 mm (0.01-inch) crack strength is desired.
- Selection of Pipe Strength
Equation 6 is used to determine the required D-load:

$$D_{0.3mm} = \left[\frac{W_E}{B_{fv}} + \frac{W_L}{B_{fLL}} \right] \times \left[\frac{F.S.}{D} \right] \times (9.81)$$

$$D_{0.3mm} = \left[\frac{3,810}{3.4} + \frac{1,000}{2.2} \right] \times \left[\frac{1.0}{900} \right] \times (9.81)$$

$$D_{0.3mm} = 17.1$$

or

$$D_{0.01} = \left[\frac{W_E}{B_{fv}} + \frac{W_L}{B_{fLL}} \right] \times \left[\frac{F.S.}{D} \right]$$

$$D_{0.01} = \left[\frac{2,560}{3.4} + \frac{670}{2.2} \right] \times \left[\frac{1.0}{3} \right]$$

$$D_{0.01} = 350$$

References

- The Theory of External Loads on Closed Conduits In the Light of the Latest Experiments**, A. Marston, Bulletin 96, Iowa State College, 1930.
- The Supporting Strength of Rigid Pipe Culverts**, M.G. Spangler, Bulletin 112, Iowa State College, 1933.
- Design Data 38, Bedding Factors - Trench Installations**, American Concrete Pipe Association, July, 1980.
- CP Information No. 12, Lateral Pressures and Bedding Factors**, American Concrete Pipe Association, 1991.
- Design Method for Reinforced Concrete Pipe and Box Sections**, F.J. Heger and T.J. McGrath, Simpson, Gumpertz and Heger, American Concrete Pipe Association, 1982.
- Concrete Pipe Handbook**, American Concrete Pipe Association, 1988.
- Concrete Pipe Design Manual**, American Concrete Pipe Association, 1992.

Answers – Example 2

Installation Type	W_E	B_{fe}	B_{fo}	B_{fv}	W_L	B_{fLL}	$D_{0.01}$
Type 1	2,560	4.0	2.3	3.4	670	2.2	350
Type 2	2,560	2.9	1.9	2.6	670	2.2	430
Type 3	2,560	2.3	1.7	2.1	670	2.1	510
Type 4	2,560	1.7	1.5	1.6	670	1.6	670
Type 1 (S.I. units)	3,810	4.0	2.3	3.4	1000	2.2	17.1
Type 2 (S.I. units)	3,810	2.9	1.9	2.6	1000	2.2	21.1
Type 3 (S.I. units)	3,810	2.3	1.7	2.1	1000	2.1	25.0
Type 4 (S.I. units)	3,810	1.7	1.5	1.6	1000	1.6	32.2

