

Standard Installations and Bedding Factors for the Indirect Design Method

Background

The classic theory of earth loads on buried concrete pipe published, in 1930 by A. Marston, was developed for trench and embankment conditions.

In later work published in 1933, M. G. Spangler presented three bedding configurations and the concept of a bedding factor to relate the supporting strength of buried pipe to the strength obtained in a three-edge bearing test.

Spangler's theory proposed that the bedding factor for a particular pipeline and, consequently, the supporting strength of the buried pipe, is dependent on two installation characteristics:

1. Width and quality of contact between the pipe and bedding.
2. Magnitude of lateral pressure and the portion of the vertical height of the pipe over which it acts.

For the embankment condition, Spangler developed a general equation for the bedding factor, which partially included the effects of lateral pressure. For the trench condition, Spangler established conservative fixed bedding factors, which neglected the effects of lateral pressure, for each of the three beddings. This separate development of bedding factors for trench and embankment conditions resulted in the belief that lateral pressure becomes effective only at transition, or greater, trench widths. Such an assumption is not compatible with current engineering concepts and construction methods. It is reasonable to expect some lateral pressure to be effective at trench widths less than transition widths. Although conservative designs based on the work of Marston and Spangler have been developed and installed successfully for years, the design concepts have their limitations when applied to real world installations.

The limitations include:

- Loads considered acting only at the top of the pipe.
- Axial thrust not considered.
- Bedding width of test installations less than width designated in his bedding configurations.
- Standard beddings developed to fit assumed

theories for soil support rather than ease of and methods of construction.

- Bedding materials and compaction levels not adequately defined.

This publication, Design Data 9, discusses the more recently developed Standard Installations and the appropriate indirect design procedures to be used with them.

Introduction

In 1970, ACPA began a long-range research program on the interaction of buried concrete pipe and soil. The research resulted in the comprehensive finite element computer program SPIDA, Soil-Pipe Interaction Design and Analysis, for the direct design of buried concrete pipe.

Since the early 1980's, SPIDA has been used for a variety of studies, including development of four new Standard Installations, and a simplified microcomputer design program, SIDD, Standard Installations Direct Design.

This Design Data 9 replaces the historical A, B, C, and D beddings used in the indirect design method with the four new Standard Installations, and presents a state-of-the-art method for determination of bedding factors for the Standard Installations. Pipe and installation terminology as used in the Installations, SIDD, and this Design Data are defined in Figure 1.

Four Standard Installations

Through consultations with engineers and contractors, and with the results of numerous SPIDA parameter studies, four new Standard Installations were developed and are presented in Table 2. The SPIDA studies were conducted for positive projection embankment conditions, which are the worst-case vertical load conditions for pipe, and which provide conservative results for other embankment and trench conditions.

The parameter studies confirmed ideas postulated from past experience and proved the following concepts:

- Loosely placed, uncompacted bedding directly under the invert of the pipe significantly reduces

Figure 1 Standard Trench/Embankment Installation

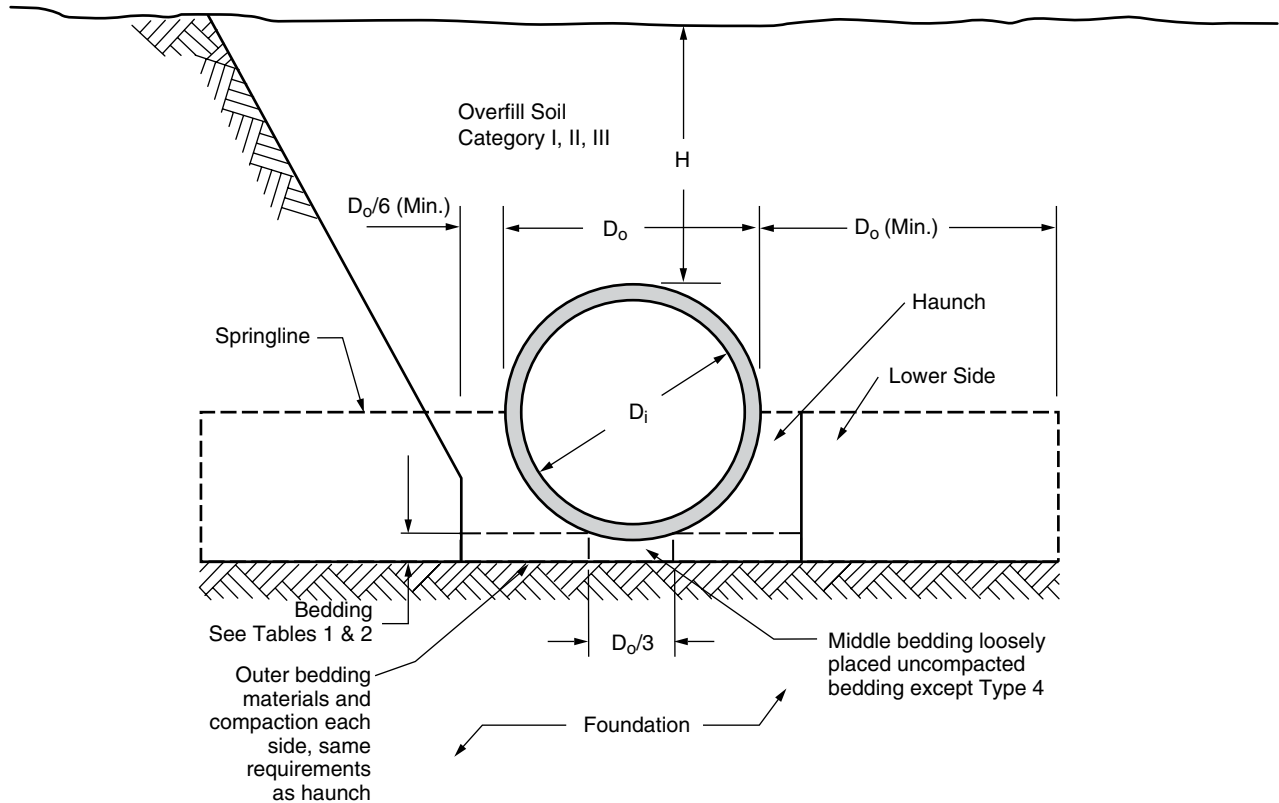

stresses in the pipe.

- Soil in those portions of the bedding and haunch areas directly under the pipe is difficult to compact.
- The soil in the haunch area from the foundation to the pipe springline provides significant support to the pipe and reduces pipe stresses.
- Compaction level of the soil directly above the haunch, from the pipe springline to the top of the pipe grade level, has negligible effect on pipe stresses. Compaction of the soil in this area is not necessary unless required for pavement structures.
- Installation materials and compaction levels below the springline have a significant effect on pipe structural requirements.

The four Standard Installations provide an optimum range of soil-pipe interaction characteristics. For the relatively high quality materials and high compaction effort of a Type 1 Installation, a lower strength pipe is required. Conversely, a Type 4 Installation requires a higher strength pipe, because it was developed for conditions of little or no control over materials or compaction.

Generic soil types are designated in Table 1. The Unified Soil Classification System (USCS) and American Association of State Highway and Transportation

Officials (AASHTO) soil classifications equivalent to the generic soil types in the Standard Installations are also presented in Table 1.

Table 1 Equivalent USCS and AASHTO Soil Classifications for SIDD Soil Designations

SIDD Soil	Representative Soil Types		Percent Compaction	
	USCS	AASHTO	Standard Proctor	Modified Proctor
Gravelly Sand (Category I)	SW, SP GW, GP	A1, A3	100	95
			95	90
			90	85
			85	80
			80	75
61	59			
Sandy Silt (Category II)	GM, SM, ML Also GC, SC with less than 20% passing #200 sieve	A2, A4	100	95
			95	90
			90	85
			85	80
			80	75
49	46			
Silty Clay (Category III)	CL, MH GC, SC	A5, A6	100	90
			95	85
			90	80
			85	75
			80	70
45	40			

Table 2 Standard Installations Soils and Minimum Compaction Requirements

Installation Type	Bedding Thickness	Haunch and Outer Bedding	Lower Side
Type 1	D _o /24 minimum, not less than 3 in. If rock foundation, use D _o /12 minimum, not less than 6 in.	95% Category I	90% Category I, 95% Category II. or 100% Category III
Type 2	D _o /24 minimum, not less than 3 in. If rock foundation, use D _o /12 minimum, not less than 6 in.	90% Category I or Category II	85% Category I, 90% Category II, or 95% Category III
Type 3	D _o /24 minimum, not less than 3 in. If rock foundation, use D _o /12 minimum, not less than 6 in.	85% Category I, 90% Category II, or 95% Category III	85% Category I, 90% Category II, or 95% Category III
Type 4	D _o /24 minimum, not less than 3 in. If rock foundation, use D _o /12 minimum, not less than 6 in.	No compaction required, except if Category III, use 85% Category III	No compaction require, except if Category III, use 85% Category III

Notes:

1. *Compaction and soil symbols - i.e. "95% Category I" - refers to Category I soil material with minimum standard Proctor compaction of 95%. See Table 1 for equivalent modified Proctor values.*
2. *Soil in the outer bedding, haunch, and lower side zones, except under the middle 1/3 of the pipe, shall be compacted to at least the same compaction as the majority of soil in the overfill zone.*
3. *For trenches, the top elevation shall be no lower than 0.1 H below finished grade or, for roadways, its top shall be no lower than an elevation of 1 foot below the bottom of the pavement base material.*
4. *For trenches, the width shall be wider than shown if required for adequate space to attain the specified compaction in the haunch and bedding zones.*
5. *For trench walls that are within 10 degrees of vertical, the compaction or firmness of the soil in the trench walls and lower side zone need not be considered.*
6. *For trench walls with greater than 10 degree slopes that consist of embankment, the lower side shall be compacted to at least the same compaction as specified for the soil in the backfill zone.*
7. *Subtrenches*
 - 7.1 *A subtrench is defined as a trench with its top below finished grade by more than 0.1 H or, for roadways, its top is at an elevation lower than 1ft. below the bottom of the pavement base material.*
 - 7.2 *The minimum width of a subtrench shall be 1.33 D_o or wider if required for adequate space to attain the specified compaction in the haunch and bedding zones.*
 - 7.3 *For subtrenches with walls of natural soil, any portion of the lower side zone in the subtrench wall shall be at least as firm as an equivalent soil placed to the compaction requirements specified for the lower side zone and as firm as the majority of soil in the overfill zone, or shall be removed and replaced with soil compacted to the specified level.*

Load Pressures

SPIDA was programmed with the Standard Installations and many design runs were made. An evaluation of the output of the designs by Dr. Frank J. Heger produced a load pressure diagram significantly different than proposed by previous theories. See Figure 2. This difference is particularly significant under the pipe in the lower haunch area and is due in part to the assumption

of the existence of partial voids adjacent to the pipe wall in this area. SIDD uses this pressure data to determine moments, thrusts, and shears in the pipe wall, and then uses the ACPA limit states design method to determine the required reinforcement areas to handle the pipe wall stresses. Using this method, each criteria that may limit or govern the design is considered separately in the evaluation of overall design requirements. SIDD, which

Figure 2 Arching Coefficients and Heger Earth Pressure Distributions

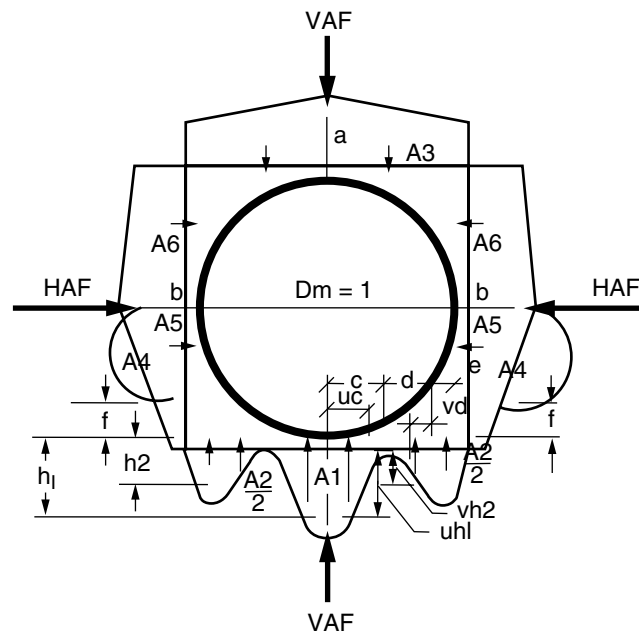

Installation															
Type	VAF	HAF	A1	A2	A3	A4	A5	A6	a	b	c	e	f	u	v
1	1.35	0.45	0.62	0.73	1.35	0.19	0.08	0.18	1.40	0.40	0.18	0.08	0.05	0.80	0.80
2	1.40	0.40	0.85	0.55	1.40	0.15	0.08	0.17	1.45	0.40	0.19	0.10	0.05	0.82	0.70
3	1.40	0.37	1.05	0.35	1.40	0.10	0.10	0.17	1.45	0.36	0.20	0.12	0.05	0.85	0.60
4	1.45	0.30	1.45	0.00	1.45	0.00	0.11	0.19	1.45	0.30	0.25	0.00	-	0.90	-

Notes:

1. VAF and HAF are vertical and horizontal arching factors. These coefficients represent non-dimensional total vertical and horizontal loads on the pipe, respectively. The actual total vertical and horizontal loads are (VAF) X (PL) and (HAF) X (PL), respectively, where PL is the prism load.
2. Coefficients A1 through A6 represent the integration of non-dimensional vertical and horizontal components of soil pressure under the indicated portions of the component pressure diagrams (i.e. the area under the component pressure diagrams). The pressures are assumed to vary either parabolically or linearly, as shown, with the non-dimensional magnitudes at governing points represented by h_1 , h_2 , uh_1 , vh_2 , a and b . Non-dimensional horizontal and vertical dimensions of component pressure regions are defined by c , d , e , vc , vd , and f coefficients.
3. d is calculated as $(0.5-c-e)$.
 h_1 is calculated as $(1.5A_1) / (c) (1+u)$.
 h_2 is calculated as $(1.5A_2) / [(d) (1+v) + (2e)]$

is based on the four Standard Installations, is a stand-alone program developed by the American Concrete Pipe Association.

The Federal Highway Administration, FHWA, developed a microcomputer program, PIPECAR, for the direct design of concrete pipe prior to the development of SIDD. PIPECAR determines moment, thrust, and shear coefficients from either of two systems, a radial pressure system developed by Olander in 1950 or a uniform pressure system developed by Paris in the 1920's, and also uses the ACPA limit states design method to determine

the required reinforcement areas to handle the pipe wall stresses. The SIDD system has been incorporated into PIPECAR as a state-of-the-art enhancement.

The SPIDA design runs with the Standard Installations were made with medium compaction of the bedding under the middle-third of the pipe, and with some compaction of the overfill above the springline of the pipe. This middle-third area under the pipe in the Standard Installations has been designated as loosely placed, uncompacted material. The intent is to maintain a slightly yielding bedding under the middle-third of the

pipe so that the pipe may settle slightly into the bedding and achieve improved load distribution. Compactive efforts in the middle-third of the bedding with mechanical compactors is undesirable, and could produce a hard flat surface, which would result in highly concentrated stresses in the pipe invert similar to those experienced in the three-edge bearing test. The most desirable construction sequence is to place the bedding to grade; install the pipe to grade; compact the bedding outside of the middle-third of the pipe; and then place and compact the haunch area up to the springline of the pipe. The bedding outside the middle-third of the pipe may be compacted prior to placing the pipe.

As indicated in Figure 1, when the design includes surface loads, the overfill and lower side areas should be compacted as required to support the surface load. With no surface loads or surface structure requirements, these areas need not be compacted.

Beddings

A bedding is provided to distribute the vertical reaction around the lower exterior surface of the pipe and reduce stress concentrations within the pipe wall. The load that a concrete pipe will support depends on the width of the bedding contact area and the quality of the contact between the pipe and bedding. An important consideration in selecting a material for bedding is to be sure that positive contact can be obtained between the bed and the pipe. Since most granular materials will shift to attain positive contact as the pipe settles, an ideal load distribution can be attained through the use of clean coarse sand, well-rounded pea gravel or well-graded crushed rock.

Design Procedure

The six-step indirect design procedure presented in the Concrete Pipe Design Manual⁷ for the selection of pipe strength is still appropriate.

1. Determination of Earth Load
2. Determination of Live Load
3. Selection of Standard Installation
5. Determination of Bedding Factor
5. Application of Factor of Safety
6. Selection of Pipe Strength

DETERMINATION OF EARTH LOAD

One of the informative calculations output by SPIDA is the arching factor, which is defined as the ratio of the calculated vertical load on the pipe to the weight of the prism of earth directly above the outside diameter of the pipe. Evaluation of the arching factor from the SPIDA studies shows that the factor approaches a value of 1.45 as an upper limit for any of the four Standard Installations.

The arching factor varies for each of the four Standard Installations and are presented in Table 3.

Embankment Soil Load

Concrete pipe can be installed in either an embankment or trench condition as discussed previously. The type of installation has a significant effect on the loads carried by the rigid pipe. Although narrow trench installations are most typical, there are many cases where the pipe is installed in a positive projecting embankment condition, or a trench with a width significant enough that it should be considered a positive projecting embankment condition. In this condition the soil along side the pipe will settle more than the soil above the rigid pipe structure, thereby imposing additional load to the prism of soil directly above the pipe. With the Standard Installations, this additional load is accounted for by using a Vertical Arching Factor. This factor is multiplied by the prism load (weight of soil directly above the pipe) to give the total load of soil on the pipe.

$$W_e = \text{VAF} \times \text{PL} \quad (1)$$

Unlike the previous design method used for the Marston/Spangler beddings there is no need to assume a projection or settlement ratio. The Vertical Arching Factors for the Standard Installations are as shown in Table 3, and the equation for soil prism load is shown below in Equation (2).

Prism Load

$$\text{PL} = w \left[H + \frac{D_o(4 - \pi)}{8} \right] D_o \quad (2)$$

w = soil unit weight, (lbs/ft³)

H = height of fill, (ft)

D_o = outside diameter of pipe, (ft)

Trench Soil Load

In narrow or moderate trench width conditions, the resulting earth load is equal to the weight of the soil within the trench minus the shearing (frictional) forces on the sides of the trench. Since the new installed backfill material will settle more than the existing soil on the sides of the trench, the friction along the trench walls will relieve the pipe of some of its soil burden. The Vertical Arching Factors in this case will be less than those used for embankment design. The backfill load on pipe installed in a trench condition is computed by the equation:

$$W_d = C_d w B_d^2 + \frac{D_o^2(4 - \pi)}{8} w \quad (3)$$

The value of C_d can be calculated using equation 4 below.

$$C_d = \frac{1 - e^{-2K\mu' \frac{H}{B_d}}}{2K\mu'} \quad (4)$$

Where:

B_d = width of trench, (ft)

K = ratio of active lateral unit pressure to vertical unit pressure

μ' = $\tan \phi$, coefficient of friction between fill material and sides of trench

Typical values of $K\mu'$ are:

$K\mu' = .1924$ Max. for granular materials without cohesion

$K\mu' = .165$ Max for sand and gravel

$K\mu' = .150$ Max. for saturated top soil

$K\mu' = .130$ Max. for ordinary clay

$K\mu' = .110$ Max for saturated clay

As trench width increases, the reduction in load from the frictional forces is offset by the increase in soil weight within the trench. As the trench width increases it starts to behave like an embankment, where the soil on the side of the pipe settles more than the soil above the pipe. Eventually, the embankment condition is reached when the trench walls are too far away from the pipe to help support the soil immediately adjacent to it. The transition width is the width of a trench at a particular depth where the trench load equals the embankment load. Once transition width is reached, there is no longer any benefit from frictional forces along the wall of the trench. Any pipe installed in a trench width equal to or greater than transition width should be designed for the embankment condition.

FLUID LOAD

Fluid weight typically is about the same order of magnitude as pipe weight and generally represents a significant portion of the pipe design load only for large diameter pipe under relatively shallow fills. Fluid weight has been neglected in the traditional design procedures of the past, including the Marston Spangler design method utilizing the B and C beddings. There is no documentation of concrete pipe failures as a result of neglecting fluid load. However, some specifying agencies such as AASHTO and CHBDC, now require that the weight of the fluid inside the pipe always be considered when determining the D-load.

The Sixteenth Edition of the AASHTO Standard Specifications For Highway Bridges states: "The weight

Table 3 Vertical Arching Factor, VAF

Standard Installation	Vertical Arching Factor, VAF
Type 1	1.35
Type 2	1.40
Type 3	1.40
Type 4	1.45

Note:

1. VAF are vertical arching factors. These coefficients represent nondimensional total vertical loads on the pipe. The actual total vertical loads are (VAF) X (PL), where PL is the prism load.

of fluid, W_f , in the pipe shall be considered in design based on a fluid weight of 62.4 lbs/cu.ft, unless otherwise specified."

DETERMINATION OF LIVE LOAD

Design Data 1 can be used to determine the live load for both the trench and embankment conditions.

SELECTION OF STANDARD INSTALLATION

The selection of a Standard Installation for a project should be based on an evaluation of the quality of construction and inspection anticipated. A Type 1 Standard Installation requires the highest construction quality and degree of inspection. Required construction quality is reduced for a Type 2 Standard Installation, and reduced further for a Type 3 Standard Installation. A Type 4 Standard Installation requires virtually no construction or quality inspection. Consequently, a Type 4 Standard Installation will require a higher strength pipe, and a Type 1 Standard Installation will require a lower strength pipe for the same depth of installation.

DETERMINATION OF BEDDING FACTOR

Under installed conditions the vertical load on a pipe is distributed over its width and the reaction is distributed in accordance with the type of bedding. When the pipe strength used in design has been determined by plant testing, bedding factors must be developed to relate the in-place supporting strength to the more severe plant test strength. The bedding factor is the ratio of the strength of the pipe under the installed condition of loading and bedding to the strength of the pipe in the plant test. This same ratio was defined originally by Spangler as the load factor. This latter term, however, was subsequently defined in the ultimate strength method of reinforced concrete design with an entirely different meaning. To avoid confusion, therefore, Spangler's term was renamed the bedding factor.

The three-edge bearing test as shown in Figure 3 is the normally accepted plant test so that all bedding

Figure 3 Three-Edge Bearing Test

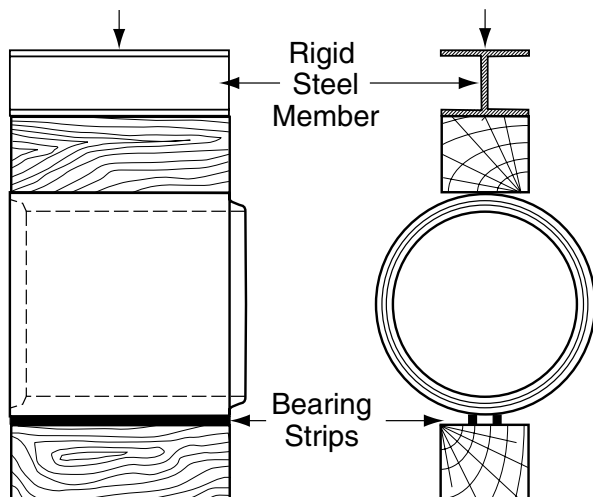

factors described in the following relate the in-place supporting strength to the three-edge bearing strength.

The Standard Installations are easier to construct and provide more realistic designs than the historical A, B, C, and D beddings. Development of bedding factors for the Standard Installations, as presented in the following paragraphs, follows the concepts of reinforced concrete design theories. The basic definition of bedding factor is that it is the ratio of maximum moment in the three-edge bearing test to the maximum moment in the buried condition, when the vertical loads under each condition are equal:

$$B_f = \frac{M_{TEST}}{M_{FIELD}} \quad (5)$$

where:

B_f = bedding factor

M_{TEST} = maximum moment in pipe wall under three-edge bearing test load, inch-pounds

M_{FIELD} = maximum moment in pipe wall under field loads, inch-pounds

Consequently, to evaluate the proper bedding factor relationship, the vertical load on the pipe for each condition must be equal, which occurs when the springline axial thrusts for both conditions are equal. In accordance with the laws of statics and equilibrium, M_{TEST} and M_{FIELD} are:

$$M_{TEST} = [0.318N_{FS}] \times [D + t] \quad (6)$$

$$M_{FIELD} = [M_{FI}] - [0.38tN_{FI}] - [0.125N_{FI} \times c] \quad (7)$$

where:

N_{FS} = axial thrust at the springline under a three-edge bearing test load, pounds per foot

D = internal pipe diameter, inches

t = pipe wall thickness, inches

M_{FI} = moment at the invert under field loading, inch-pounds/ft

N_{FI} = axial thrust at the invert under field loads, pounds per foot

c = thickness of concrete cover over the inner reinforcement, inches

Substituting equations 6 and 7 into equation 5.

$$B_f = \frac{[0.318N_{FS}] \times [D+t]}{[M_{FI}] - [0.38tN_{FI}] - [0.125N_{FI} \times c]} \quad (8)$$

Using SIDD, bedding factors were determined for a range of pipe diameters and depths of burial. These calculations were based on one inch cover over the reinforcement, a moment arm of 0.875d between the resultant tensile and compressive forces, and a reinforcement diameter of 0.075t. Evaluations indicated that for A, B and C pipe wall thicknesses there was negligible variation in the bedding factor due to pipe wall thickness or the concrete cover, c, over the reinforcement. The resulting bedding factors are presented in Table 4.

Table 4 Bedding Factors, Embankment Condition, B_{fe}

Pipe Diameter	Standard installation			
	Type 1	Type 2	Type 3	Type 4
12 in.	4.4	3.2	2.5	1.7
24 in.	4.2	3.0	2.4	1.7
36 in.	4.0	2.9	2.3	1.7
72 in.	3.8	2.8	2.2	1.7
144 in.	3.6	2.8	2.2	1.7

Notes:

1. For pipe diameters other than listed in Table 4, embankment condition factors, B_{fe} can be obtained by interpolation.
2. Bedding factors are based on the soils being placed with the minimum compaction specified in Table 2 for each standard installation.

The use of the Standard Installations and bedding factors presented in this Design Data simplifies the indirect design procedure. Changes to and use of each step of the design procedure are described in the following paragraphs.

Table 4 presents embankment bedding factors, B_{fe} , for each of the Standard Installations. For trench installations as discussed in C. P. Info No. 12⁴ and in

Figure 4 Variable Bedding Factor

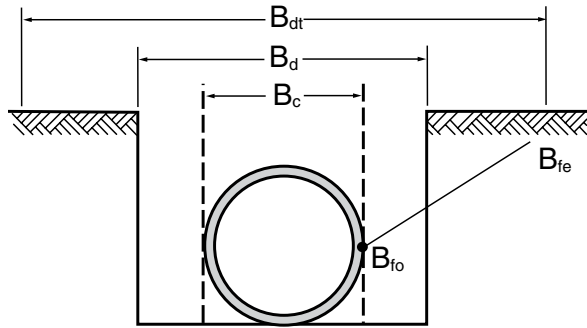

the Design Manual⁷, experience indicates that active lateral pressure increases as trench width increases to the transition width, provided the sidefill is compacted. A SIDD parameter study of the Standard Installations indicates the bedding factors are constant for all pipe diameters under conditions of zero lateral pressure on the pipe. These bedding factors exist at the interface of the pipewall and the soil and are called minimum bedding factors, B_{to} , shown in Figure 4, to differentiate them from the fixed bedding factors developed by Spangler. Table 5 presents the minimum bedding factors.

Table 5 Trench Minimum Bedding Factors, B_{to}

Standard Installation	Minimum Bedding Factor, B_{to}
Type 1	2.3
Type 2	1.9
Type 3	1.7
Type 4	1.5

Note:

1. Bedding factors are based on the soils being placed with the minimum compaction specified in Table 2 for each Standard Installation.
2. For pipe installed in trenches dug in previously constructed embankment, the load and the bedding factor should be determined as an embankment condition unless the backfill placed over the pipe is of lesser compaction than the embankment

The equation for the variable trench bedding factor modified for use with the Standard Installations, is:

$$B_{fv} = \frac{[B_{fe} - B_{to}][B_d - B_c]}{[B_{dt} - B_c]} + B_{to} \quad (9)$$

where:

- B_c = outside horizontal span of pipe, feet
- B_d = trench width at top of pipe, feet
- B_{dt} = transition width at top of pipe, feet
- B_{fe} = bedding factor, embankment
- B_{to} = minimum bedding factor, trench
- B_{fv} = variable bedding factor, trench

A conservative linear variation is assumed between the minimum bedding factor and the bedding factor for the embankment condition, which begins at transition width.

The Design Manual (Tables 13 through 39) presents transition width values for use in the preceding equation.

For pipe installed with 6.5 ft or less of overfill and subjected to truck loads, the controlling maximum moment may be at the crown rather than the invert. Consequently, the use of an earth load bedding factor may produce unconservative designs. Crown and invert moments of pipe for a range of diameters and burial depths subjected to HS20 truck live loadings were evaluated. Also evaluated, was the effect of bedding angle and live load angle (width of loading on the pipe). When HS20 or other live loadings are encountered to a significant value, the live load bedding factors, B_{ILL} , presented in Table 6 are satisfactory for a Type 4 Standard Installation and become increasingly conservative for Types 3, 2, and 1. Limitations on B_{ILL} are discussed in the section on Selection of Pipe Strength.

APPLICATION OF FACTOR OF SAFETY

The indirect design method for concrete pipe is similar to the common working stress method of steel design, which employs a factor of safety between yield stress and the desired working stress. In the indirect method, the factor of safety is defined as the relationship between the ultimate strength D -load and the 0.01 inch crack D -load. This relationship is specified in the ASTM Standards C 76 and C 655 on concrete pipe. The relationship between ultimate D -load and 0.01-inch crack D -load is 1.5 for 0.01 inch crack D -loads of 2,000 or less; 1.25 for 0.01 inch crack D -loads of 3,000 or more; and a linear reduction from 1.5 to 1.25 for 0.01 inch crack D -loads between more than 2,000 and less than 3,000. Therefore, a factor of safety of 1.0 should be applied if the 0.01 inch crack strength is used as the design criterion rather than the ultimate strength. The 0.01 inch crack width is an arbitrarily chosen test criterion and not a criteria for field performance or service limit.

SELECTION OF PIPE STRENGTH

The American Society for Testing and Materials has developed standard specifications for precast concrete pipe. Each specification contains design, manufacturing and testing criteria.

ASTM Standard C 14 covers three strength classes for nonreinforced concrete pipe. These classes are specified to meet minimum ultimate loads, expressed in terms of three-edge bearing strength in pounds per linear foot.

ASTM Standard C 76 for reinforced concrete culvert, storm drain and sewer pipe specifies strength classes

Table 6 Bedding Factors, B_{fLL} , for HS20 Live Loadings

Fill Height	Pipe Diameter, Inches										
	12	24	36	48	60	72	84	96	108	120	144
0.5	2.2	1.7	1.4	1.3	1.3	1.1	1.1	1.1	1.1	1.1	1.1
1.0	2.2	2.2	1.7	1.5	1.4	1.3	1.3	1.3	1.1	1.1	1.1
1.5	2.2	2.2	2.1	1.8	1.5	1.4	1.4	1.3	1.3	1.3	1.1
2.0	2.2	2.2	2.2	2.0	1.8	1.5	1.5	1.4	1.4	1.3	1.3
2.5	2.2	2.2	2.2	2.2	2.0	1.8	1.7	1.5	1.4	1.4	1.3
3.0	2.2	2.2	2.2	2.2	2.2	2.2	1.8	1.7	1.5	1.5	1.4
3.5	2.2	2.2	2.2	2.2	2.2	2.2	1.9	1.8	1.7	1.5	1.4
4.0	2.2	2.2	2.2	2.2	2.2	2.2	2.1	1.9	1.8	1.7	1.5
4.5	2.2	2.2	2.2	2.2	2.2	2.2	2.2	2.0	1.9	1.8	1.7
5.0	2.2	2.2	2.2	2.2	2.2	2.2	2.2	2.2	2.0	1.9	1.8
5.5	2.2	2.2	2.2	2.2	2.2	2.2	2.2	2.2	2.2	2.0	1.9
6.0	2.2	2.2	2.2	2.2	2.2	2.2	2.2	2.2	2.2	2.1	2.0
6.5	2.2	2.2	2.2	2.2	2.2	2.2	2.2	2.2	2.2	2.2	2.2

Note:

- For pipe diameters other than listed in Table 6, B_{fLL} values can be obtained by interpolation.

based on D -load at 0.01-inch crack and/or ultimate load as shown below in Table 7. The 0.01-inch crack D -load ($D_{0.01}$) is the maximum three-edge-bearing test load supported by a concrete pipe before a crack occurs having a width of 0.01 inch measured at close intervals, throughout a length of at least 1 foot. The ultimate D -load (D_{ult}) is the maximum three-edge-bearing test load supported by a pipe divided by the pipe's inside diameter. D -loads are expressed in pounds per linear foot per foot of inside diameter.

ASTM Standard C 655 for reinforced concrete D -load culvert, storm drain and sewer pipe covers acceptance of pipe designed to meet specific D -load requirements.

ASTM Standard C 985 for nonreinforced concrete specified strength culvert, storm drain, and sewer pipe covers acceptance of pipe designed for specified strength requirements.

Since numerous reinforced concrete pipe sizes are available, three-edge bearing test strengths are classified by D -loads. The D -load concept provides strength classification of pipe independent of pipe diameter. For reinforced circular pipe the three-edge-bearing test load in pounds per linear foot equals D -load times inside diameter in feet.

The required three-edge-bearing strength of non-reinforced concrete pipe is expressed in pounds per linear foot, not as a D -load, and is computed by the equation:

$$T.E.B = \left[\frac{W_E}{B_f} + \frac{W_L}{B_{fLL}} \right] \times F.S. \quad (10)$$

The required three-edge bearing strength of circular reinforced concrete pipe is expressed as D -load and is computed by the equation:

$$D\text{-load} = \left[\frac{W_E}{B_f} + \frac{W_L}{B_{fLL}} \right] \times \frac{F.S.}{D} \quad (11)$$

When an HS20 truck live loading is applied to the pipe, use the live load bedding factor, B_{fLL} , as indicated in Equations 10-11, unless the earth load bedding factor, B_f , is of lesser value in which case, use the lower B_f value in place of B_{fLL} . For example, with a Type 4 Standard Installation of a 48 inch diameter pipe under 1.0 feet of fill, the factors used would be $B_f = 1.7$ and $B_{fLL} = 1.5$; but under 2.5 feet or greater fill, the factors used would be $B_f = 1.7$ and $B_{fLL} = 1.7$ rather than 2.2. For trench installations with trench widths less than transition width, B_{fLL} would be compared to the variable trench bedding factor, B_{fv} .

The use of the six-step indirect design method is illustrated by an example on the following pages.

Table 7 Reinforced Pipe Classes for 0.01 inch Crack Per ASTM C 76 (lbs/ft/ft)

Class I	≤ 800
Class II	≤ 1000
Class III	≤ 1350
Class IV	≤ 2000
Class V	≤ 3000
Special Design	> 3000

EXAMPLE PROBLEM

Positive Projection Embankment Installation

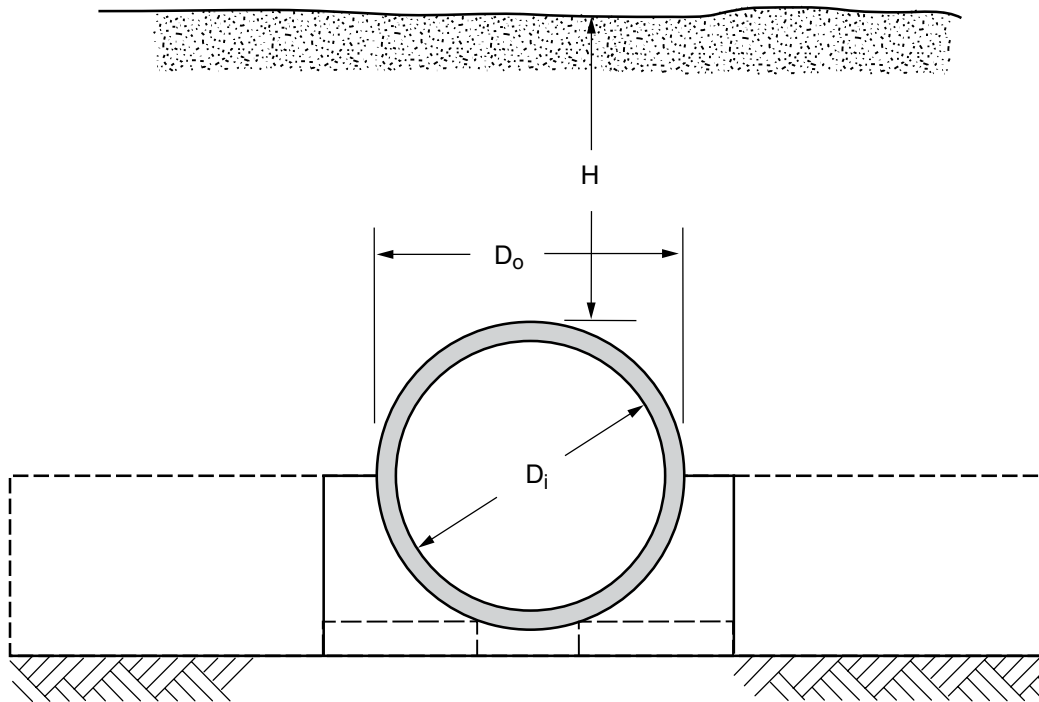

Given: A 48 inch circular pipe is to be installed in a positive projecting embankment condition using a Type 1 installation. The pipe will be covered with 35 feet of 120 pounds per cubic foot overfill.

Find: The required pipe strength in terms of 0.01 inch crack D-load.

1. Determination of Earth Load (W_E)

Per the given information, the installation behaves as a positive projecting embankment. Therefore, use Equation 2 to determine the soil prism load and multiply it by the appropriate vertical arching factor.

$$D_o = \frac{48 + 2(5)}{12} \quad \text{Note: The wall thickness for a 48-inch pipe with a B wall is 5-inches per ASTM C76.}$$

$$D_o = 4.83 \text{ outside diameter of pipe in feet}$$

$$w = 120 \text{ unit weight of soil in pounds per cubic foot}$$

$$H = 35 \text{ height of cover in feet}$$

$$PL = 120 \left[35 + \frac{4.83(4-\pi)}{8} \right] 4.83$$

$$PL = 20,586 \text{ pounds per linear foot}$$

Immediately listed below Equation 1 are the vertical arching factors (VAFs) for the four types of Standard Installations. Using a VAF of 1.35 for a Type 1 Installation, the earth load is:

$$W_E = 1.35 \times 20,586$$

$$W_E = 27,791 \text{ pounds per linear foot}$$

$$\begin{aligned} \text{Fluid Load, } \gamma_w &= 62.4 \text{ lbs/ft}^3 \\ W_F &= \gamma_w * A \\ W_F &= 62.4 (\pi) \left(\frac{48}{12}\right)^2 \\ W_F &= 784 \text{ lb/ft} \end{aligned}$$

2. Determination of Live Load (W_L)

From Table 42 in the Design Manual, live load is negligible at a depth of 35 feet.

3. Selection of Bedding

A Type 1 Installation will be used for this example

4. Determination of Bedding Factor

The embankment bedding factor for a Type 1 Installation may be interpolated from Table 4

$$\begin{aligned} B_{fe36} &= 4.0 \\ B_{fe72} &= 3.8 \\ B_{fe48} &= \frac{72-48}{72-36} (4.0-3.8) + 3.8 \\ B_{fe48} &= 3.93 \end{aligned}$$

5. Application of Factor of Safety (F.S.)

A factor of safety of 1.0 based on the 0.01 inch crack will be applied.

6. Selection of Pipe Strength

The D-load is given by Equation 11

$$\begin{aligned} W_E &= 27,791 \text{ earth load in pounds per linear foot} \\ W_F &= 784 \text{ fluid load in pounds per linear foot} \\ W_L &= 0 \text{ live load is negligible} \\ B_f &= 3.93 \text{ earth load bedding factor} \\ B_{fLL} &= \text{N/A live load bedding factor is not applicable} \\ D &= 4 \text{ inside diameter of pipe in feet} \\ D_{0.01} &= \left(\frac{27,791 + 784}{3.93}\right) \times \left(\frac{1.0}{4}\right) \\ D_{0.01} &= 1,768 \text{ pounds per linear foot per foot of diameter} \end{aligned}$$

Answer: A pipe which would withstand a minimum three-edge bearing test for the 0.01 inch crack of 1,818 pounds per linear foot per foot of inside diameter would be required.

References

1. **The Theory of External Loads on Closed Conduits in the Light of the Latest Experiments**, A. Marston, Bulletin 96, Iowa State College, 1930.
2. **The Supporting Strength of Rigid Pipe Culverts**, M.G. Spangler, Bulletin 112, Iowa State College, 1933.
3. **Design Data 38, Bedding Factors – Trench Installations**, American Concrete Pipe Association, July, 1980.
4. **CP Information No. 12, Lateral Pressures and Bedding Factors**, American Concrete Pipe Association, 1991.
5. **Design Method for Reinforced Concrete Pipe and Box Sections**, F.J. Heger and T.J. McGarth, Simpson, Gumpertz and Heger, American Concrete Pipe Association, 1992.
6. **Concrete Pipe Handbook**, American Concrete Pipe Association, 1988.
7. **Concrete Pipe Design Manual**, American Concrete Pipe Association, 1992.